

Series

系列

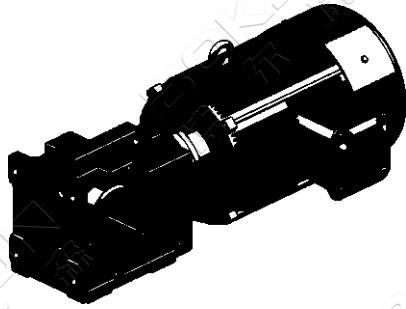



K系列减速机有以下设计方案:

K series gear units are available in the following designs:

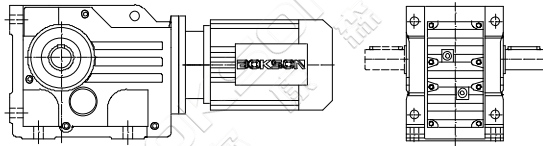

K..Y..
底脚轴伸式安装螺旋锥齿轮减速机
Foot-mounted helical-bevel gear units with solid shaft

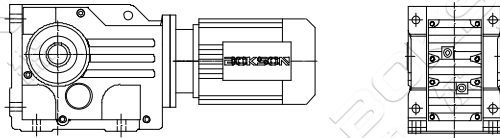

KAB...Y..
底脚空心轴安装螺旋锥齿轮减速机
Foot-mounted helical-bevel gear units with hollow shaft

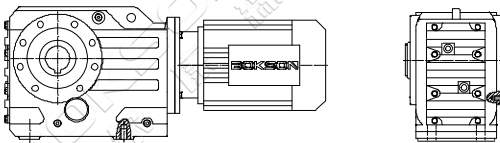

KA...Y..
空心轴安装螺旋锥齿轮减速机
Helical-bevel gear units with hollow shaft

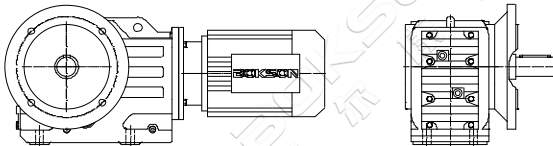

KF...Y..
法兰轴伸式安装螺旋锥齿轮减速机
Flange-mounted helical-bevel gear units with solid shaft

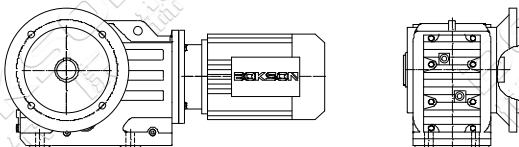

KAF...Y..
法兰空心轴安装螺旋锥齿轮减速机
Flange-mounted helical-bevel gear units with hollow shaft

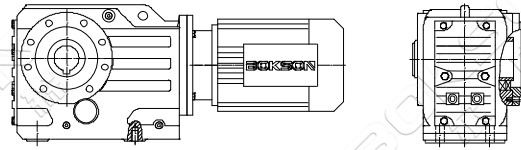

KAZ...Y..
小法兰空心轴安装螺旋锥齿轮减速机
Short-flange-mounted helical-bevel gear units with hollow shaft

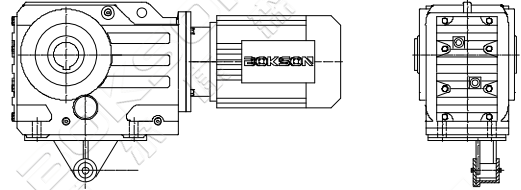

KAT...Y..
带防转臂空心轴安装螺旋锥齿轮减速机
Torque-arm-mounted helical-bevel gear units with hollow shaft

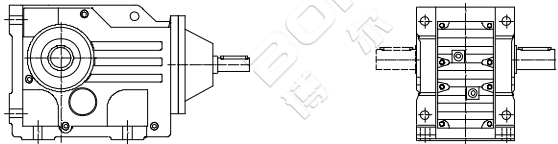

K (KF, KA, KAF, KAB, KAZ) S...
轴输入的螺旋锥齿轮减速机
Shaft input helical-bevel gear units

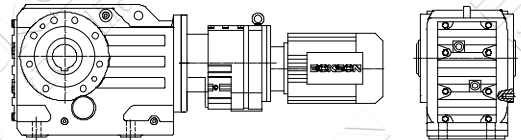

KA (K, KF, KAF, KAB, KAZ) ...R...Y...
组合式螺旋锥齿轮减速机
Combinatorial helical-bevel gear units

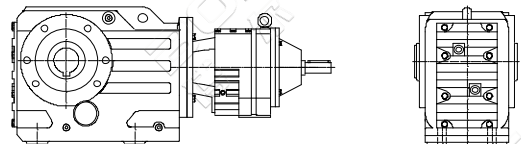

KA (K, KF, KAF, KAB, KAZ) S...R...
轴输入的组合式螺旋锥齿轮减速机
Shaft input combinatorial helical-bevel gear units

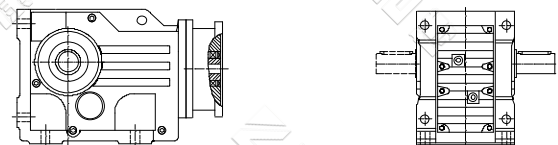

KA (K, KF, KAF, KAB, KAZ) ...Y...
电机用户自配或配特殊电机时需加联接法兰
When equipping the user's motor or the special one, the flange is required to be connected





型号与标记: Type Designations:

K F37-Y 0.55-4P-24.99-M1-180°-A-CW	K F37-Y 0.55-4P-24.99-M1-180°-A-CW
减速机类型 结构形式 机座号 电机代号 电机功率、极数 传动比 安装形式 电机接线盒位置 输出轴、锁紧盘或法兰方向 输出轴旋转方向	Gear units type Structure Size Motor code Motor power、pole Ratio Mounting position Position of the motor thermal box Position of output shaft, shrink disk or flang Rotate direction of output shaft
减速机类型: 斜齿-螺旋锥齿轮减速机	Gear units type: Helical-bevel gear units
结构形式: 普通轴伸式(省略) 轴装式 A 轴伸法兰式 F 轴装法兰式 AF 轴装小法兰式 AZ 轴装底脚式 AB 轴装带防转臂 AT 普通轴伸式, 轴输入 S 普通轴装式, 轴输入 AS 轴伸法兰式, 轴输入 FS 轴装法兰式, 轴输入 AFS *带锁紧盘式 H.. (H, HF, HZ, HT)	Structure: Foot-mounted solid shaft output (-) Hollow shaft output A Flange-mounted solid shaft output F Flange-mounted hollow shaft output AF Short-flange-mounted hollow shaft output AZ Foot-mounted hollow shaft output AB Torque-arm-mounted hollow shaft output AT Foot-mounted solid shaft output, shaft input S Hollow shaft output, shaft input AS Flange-mounted solid shaft output, shaft input FS Flange-mounted hollow shaft output, shaft input AFS *Hollow shaft output with shrink disk H.. H.. (H, HF, HZ, HT)
规格: (见选型参数表)	Size: (see selection table)
电机代号: 普通(更新) Y(Y2) 防爆 B 直流 Z 制动 YEJ 多速 D 变频 YVP 电磁调速 YCT 冶金起重 R 变频制动 YVPJ 辊道 G	Motor code: Ordinary(renew) Y(Y2) Flame-proof B Direct current Z Brake YEJ Multi-speed D Variable frequency YVP Electromagnetism speed modulation YCT Hoisting in metallurgy R Variable frequency and brake YVPJ Roller tables G
电机功率、极数: (见选型参数表)	Motor power、pole: (see selection table)
传动比: (见选型参数表)	Ratio: (see selection table)
安装形式: M1、M2、M3、M4、M5、M6(见第89页)	Mounting position: M1、M2、M3、M4、M5、M6(see page 89)
电机接线盒位置: 0°、90°、180°、270°(见第89页)	Position of the motor thermal box: 0°、90°、180°、270°(see page 89)
输出轴或法兰方向: 从电机尾部看左边为 A 从电机尾部看右边为 B (见安装形式) 从电机尾部看左右边为 A+B	Position of output shaft or flange: viewing on motor end:left side-A, right side-B,both sides-A+B(see mounting position)
输出轴旋转方向(面对输出轴方向): 顺时针方向 CW 逆时针方向 CCW	Rotate direction of output shaft (viewing on output shaft): Clockwise CW Counter clockwise CCW

*带锁紧盘式, 详见160-161页。

*Hollow shaft output with shrink disk, see P160-161 for detail.

安装形式：
Mounting position:

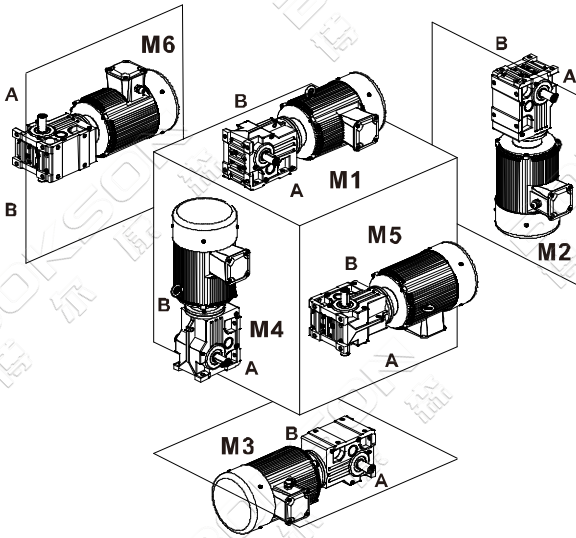

带法兰盘的安装方式也可参考左图
M1、M2、M3、M4、M5、M6

电机接线盒位置：
Position of the motor thermal box:

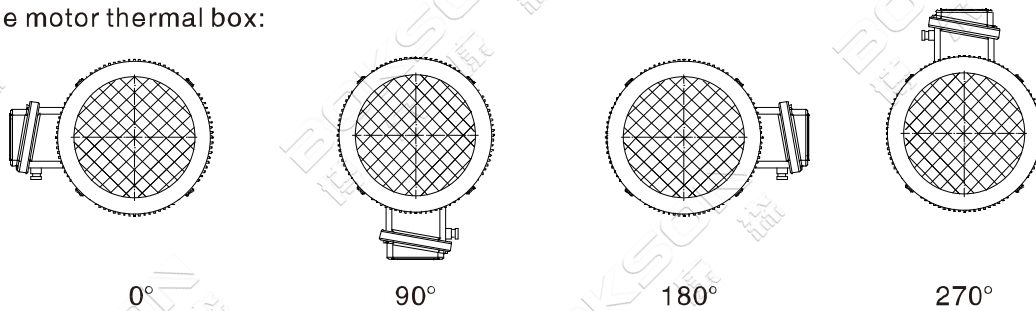

输入功率及许用转矩
Input power rating and permissible torque

规格 Size	37	47	57	67	77	87	97	107	127	157	167	187
结构形式 Structure	K KA KF KAF KAZ KAT KAB											
输入功率 Input power rating(kW)	0.18~3.0	0.18~3.0	0.18~5.5	0.18~5.5	0.37~11	0.75~22	1.1~30	3~45	7.5~90	11~160	11~200	18.5~200
传动比 Ratio	5.36~106.38	5.81~131.87	6.57~145.14	7.14~144.79	7.24~192.18	7.19~197.37	8.95~176.05	8.74~141.46	8.68~146.07	12.65~150.41	17.28~163.91	17.27~180.78
许用转矩 (N.m) Permissible torque	200	400	600	820	1550	2700	4300	8000	13000	18000	32000	50000

减速机重量
Gear unit weight

规格 Size	37	47	57	67	77	87	97	107	127	157	167	187
重量 (kg) Weight	11	20	27	33	57	85	130	250	380	610	1015	1700

所注重量为平均值, 仅供参考
The weights are mean values, only for reference.

润滑油量表
 Lubrication table

K...,KAB...:

规格 Size	润滑油量(升)			Fill quantity in liters		
	M1	M2	M3	M4	M5	M6
K..37	0.5	1	1	1.3	1	1
K..47	0.8	1.3	1.5	2	1.6	1.6
K..57	1.2	2.3	2.5	3	2.6	2.4
K..67	1.1	2.4	2.6	3.4	2.6	2.6
K..77	2.2	4.1	4.4	5.9	4.2	4.4
K..87	3.7	8	8.7	10.9	7.8	8
K..97	7	14	15.7	20	15.7	15.5
K..107	10	21	25.5	33.5	24	24
K..127	21	41.5	44	54	40	41
K..157	31	62	65	90	58	62
K..167	35	100	100	125	85	85
K..187	60	170	170	205	130	130

KF...:

规格 Size	润滑油量(升)			Fill quantity in liters		
	M1	M2	M3	M4	M5	M6
KF37	0.5	1.1	1.1	1.5	1	1
KF47	0.8	1.3	1.7	2.2	1.6	1.6
KF57	1.3	2.3	2.7	3	2.9	2.7
KF67	1.1	2.4	2.8	3.6	2.7	2.7
KF77	2.1	4.1	4.4	6	4.5	4.5
KF87	3.7	8.2	9	11.9	8.4	8.4
KF97	7	14.7	17.3	21.5	15.7	16.5
KF107	10	22	26	35	25	25
KF127	21	41.5	46	55	41	41
KF157	31	66	69	92	62	62

KA..., KAF..., KAZ...:

规格 Size	润滑油量(升)			Fill quantity in liters		
	M1	M2	M3	M4	M5	M6
K..37	0.5	1	1	1.4	1	1
K..47	0.8	1.3	1.6	2.1	1.6	1.6
K..57	1.3	2.3	2.7	3	2.9	2.7
K..67	1.1	2.4	2.7	3.6	2.6	2.6
K..77	2.1	4.1	4.6	6	4.4	4.4
K..87	3.7	8.2	8.8	11.1	8	8
K..97	7	14.7	15.7	20	15.7	15.7
K..107	10	20.5	24	32	24	24
K..127	21	41.5	43	52	40	40
K..157	31	66	67	87	62	62
KA..167	35	100	100	125	85	85
KA..187	60	170	170	205	130	130



输出转速 Output speed r/min	输出扭矩 Output torque Nm	传动比 Ratio i	使用系数 Service factor f _s	机型号 Type Type	极数 Pole p	输出转速 Output speed r/min	输出扭矩 Output torque Nm	传动比 Ratio i	使用系数 Service factor f _s	机型号 Type Type	极数 Pole p
0.18kW						0.18kW					
0.09	16482	14975	0.74			1.5	994	903	0.78		
0.11	13692	12440	0.89			1.8	873	793	0.88		
0.13	12013	10914	1.0			2.0	767	697	1.0		
0.14	10807	9819	1.1			2.3	675	613	1.1	K 67R37	4
0.16	9293	8443	1.3	K 127R77	4	2.6	597	542	1.3	KF 67R37	4
0.19	8236	7483	1.5	KF 127R77	4	3.0	518	471	1.5	KA 67R37	4
0.21	7226	6565	1.7	KA 127R77	4	3.3	462	420	1.7	KAF67R37	4
0.24	6388	5804	1.9	KAF127R77	4	3.9	397	361	1.9		
0.28	5533	5027	2.2			4.3	356	323	2.2		
0.31	4868	4423	2.5			5.1	299	272	2.6		
0.37	4184	3801	2.9								
0.43	3563	3237	3.4								
0.17	9037	8211	0.8			2.3	677	615	0.8		
0.19	7888	7167	1.0			2.6	599	544	0.9		
0.23	6711	6097	1.1			2.9	521	473	1.1		
0.25	6144	5582	1.2			3.3	463	421	1.2	K 57R37	4
0.27	5575	5065	1.3	K 107R77	4	3.8	398	362	1.4	KE 57R37	4
0.32	4732	4299	1.6	KF 107R77	4	4.4	351	319	1.6	KA 57R37	4
0.37	4135	3757	1.8	KA 107R77	4	5.1	300	273	1.9	KAF57R37	4
0.43	3562	3236	2.1	KAF107R77	4	5.8	264	240	2.1		
0.48	3158	2869	2.4			6.5	237	215	2.4		
0.56	2756	2504	2.7			7.2	211	192	2.7		
0.63	2425	2203	3.1			8.4	183	166	3.1		
0.30	5139	4669	0.79			3.7	413	375	0.9		
0.34	4493	4082	0.90			4.3	359	326	1.0		
0.39	3944	3583	1.0			4.8	318	289	1.2	K 47R37	4
0.45	3421	3108	1.2			5.6	275	250	1.4	KF 47R37	4
0.50	3035	2757	1.3			6.2	248	225	1.5	KA 47R37	4
0.57	2662	2419	1.5			7.0	218	198	1.7	KAF47R37	4
0.65	2337	2123	1.7	K 97R57	4	8.3	184	167	2.0		
0.75	2043	1856	2.0	KF 97R57	4	9.3	164	149	2.3		
0.86	1789	1625	2.3	KA 97R57	4	11	141	128	2.7		
0.97	1574	1430	2.6	KAF97R57	4	6.8	226	205	0.83	K 37R17	4
1.1	1388	1261	2.9			7.7	199	181	0.94	KF 37R17	4
1.3	1213	1102	3.3			8.7	176	160	1.07	KA 37R17	4
1.5	1053	957	3.8			10	150	136	1.26	KAF37R17	4
1.6	941	855	4.3			11	140	127	1.34		
1.9	818	743	4.9			5.9	275	144.79	2.8	K 67	6
2.1	717	651	5.6			6.9	235	123.54	3.3	KF 67	6
						7.9	205	108.03	3.8	KA 67	6
						8.3	195	102.62	4.0	KAF67	6
0.45	3420	3107	0.74			9.6	168	144.79	4.6	K 67	4
0.51	3003	2728	0.85			11	144	123.54	5.4	KF 67	4
0.59	2610	2371	0.97			13	126	108.03	6.1	KA 67	4
0.67	2298	2088	1.1							KAF67	4
0.75	2041	1854	1.2	K 87R57	4	5.9	276	145.14	2.0	K 57	6
0.84	1825	1658	1.4	KF 87R57	4	6.9	235	123.85	2.4	KF 57	6
1.0	1557	1415	1.6	KA 87R57	4	7.8	206	108.29	2.7	KA 57	6
1.1	1353	1229	1.9	KAF87R57	4	8.3	196	102.88	2.9	KAF57	6
1.3	1187	1078	2.1			9.4	172	90.26	3.3		
1.5	1047	951	2.4								
1.7	921	837	2.8			9.6	169	145.14	3.3	K 57	4
1.9	799	726	3.2			11	144	123.85	3.9	KF 57	4
						13	126	108.29	4.5	KA 57	4
0.9	1666	1514	0.9			14	120	102.88	4.7	KAF57	4
1.0	1528	1388	1.0	K 77R37	4	15	105	90.26	5.4		
1.1	1341	1218	1.1	KF 77R37	4	18	89	76.56	6.3		
1.3	1159	1053	1.3	KA 77R37	4	6.4	251	131.87	1.50	K 47	6
1.5	1017	924	1.4	KAF77R37	4	7.0	231	121.48	1.63	KF 47	6
1.7	897	815	1.6			8.1	198	104.37	1.90	KA 47	6
2.0	780	709	1.9			9.4	173	90.86	2.2	KAF47	6
2.2	685	622	2.1			10	162	85.12	2.3		
2.5	608	552	2.4								
2.9	534	485	2.7								
3.2	471	428	3.1								
3.8	404	367	3.6								





输出转速 Output speed r/min	输出扭矩 Output torque Nm	传动比 Ratio i	使用系数 Service factor f _B	机型号 Type Type	极数 Pole p	输出转速 Output speed r/min	输出扭矩 Output torque Nm	传动比 Ratio i	使用系数 Service factor f _B	机型号 Type Type	极数 Pole p
0.18kW						0.25kW					
11	153	131.87	2.5	K 47	4	0.86	2484	1625	1.6		
12	141	121.48	2.7	KF 47	4	1.0	2186	1430	1.8	K 97R57	4
13	121	104.37	3.1	KA 47	4	1.1	1928	1261	2.1	KF 97R57	4
15	106	90.86	3.6	KAF47	4	1.3	1685	1102	2.4	KA 97R57	4
16	99	85.12	3.8			1.5	1463	957	2.8	KAF97R57	4
8.0	202	106.38	0.93	K 37	6	1.6	1307	855	3.1		
8.7	186	97.81	1.01	KF 37	6	0.7	3192	2088	0.80		
10	159	83.69	1.18	KA 37	6	0.7	2834	1854	0.90		
12	138	72.54	1.36	KAF37	6	0.8	2535	1658	1.0		
13	124	106.38	1.52			1.0	2163	1415	1.2	K 87R57	4
14	114	97.81	1.65			1.1	1879	1229	1.4	KF 87R57	4
17	97	83.69	1.93			1.3	1648	1078	1.5	KA 87R57	4
19	84	72.54	2.2			1.5	1454	951	1.7	KAF87R57	4
21	79	67.80	2.4			1.7	1280	837	2.0		
24	68	58.60	2.8			1.9	1110	726	2.3		
28	58	49.79	3.2			2.2	975	638	2.6		
31	52	44.46	3.6			1.3	1610	1053	0.9		
37	44	37.97	4.3			1.5	1413	924	1.0		
39	41	35.57	4.5	K 37	4	1.7	1246	815	1.2		
46	35	29.96	5.4	KF 37	4	2.0	1084	709	1.3		
48	34	28.83	5.6	KA 37	4	2.2	951	622	1.5		
56	29	24.99	6.5	KAF37	4	2.5	844	552	1.7		
60	27	23.36	6.7			2.9	741	485	2.0	K 77R37	4
69	23	20.19	7.4			3.2	654	428	2.2	KF 77R37	4
81	20	17.15	8.5			3.9	547	358	2.7	KA 77R37	4
91	18	15.31	9.2			4.3	489	320	3.0	KAF77R37	4
106	15	13.08	10			4.9	433	283	3.4		
114	14	12.14	11			5.7	376	246	3.9		
133	12	10.49	12			6.4	330	216	4.4		
156	10	8.91	15			7.3	292	191	5.0		
175	9	7.96	16			8.2	260	170	5.6		
0.25kW						0.25kW					
0.14	15010	9819	0.81			2.3	937	613	0.8		
0.16	12907	8443	0.95			2.6	829	542	0.9		
0.19	11438	7482	1.07	K 127R77	4	3.0	720	471	1.1	K 67R37	4
0.21	10036	6565	1.2	KF 127R77	4	3.3	642	420	1.2	KF 67R37	4
0.24	8872	5804	1.4	KA 127R77	4	3.9	552	361	1.4	KA 67R37	4
0.28	7685	5027	1.6	KAF127R77	4	4.3	494	323	1.6	KAF67R37	4
0.31	6761	4423	1.8			5.1	416	272	1.9		
0.37	5811	3801	2.1			5.8	367	240	2.1		
0.43	4948	3237	2.5			6.4	332	217	2.3		
0.23	9320	6097	0.81			3.3	644	421	0.9		
0.25	8533	5582	0.88			3.8	553	362	1.0		
0.27	7743	5065	1.0			4.4	488	319	1.2		
0.32	6572	4299	1.1			5.1	417	273	1.4		
0.37	5743	3757	1.3			5.8	367	240	1.5	K 57R37	4
0.43	4947	3236	1.5	K 107R77	4	6.5	329	215	1.7	KF 57R37	4
0.48	4386	2869	1.7	KF 107R77	4	7.2	294	192	1.9	KA 57R37	4
0.56	3828	2504	2.0	KA 107R77	4	8.4	254	166	2.2	KAF57R37	4
0.63	3368	2203	2.2	KAF107R77	4	9.9	216	141	2.6		
0.74	2857	1869	2.6			11	193	126	2.9		
0.82	2582	1689	2.9			13	165	108	3.4		
0.91	2343	1533	3.2			15	145	95	3.9		
1.06	2013	1317	3.7			4.2	536	154.02	2.7	K 77	8
0.45	4751	3108	0.9	K 97R57	4	4.8	471	135.28	3.1	KF 77	8
0.50	4215	2757	1.0	KF 97R57	4	5.0	447	128.52	3.3	KA 77	8
0.57	3698	2419	1.1	KA 97R57	4	5.7	395	113.56	3.7	KAF77	8
0.65	3245	2123	1.2	KAF97R57	4	4.4	507	192.18	2.9	K 77	6
0.75	2837	1856	1.4			4.7	474	179.37	3.1	KF 77	6
						5.5	407	154.02	3.6	KA 77	6
						6.3	357	135.28	4.1	KAF77	6

K



输出转速 Output speed r/min	输出扭矩 Output torque Nm	传动比 Ratio i	使用系数 Service factor f _s	机型号 Type Type	极数 Pole p	输出转速 Output speed r/min	输出扭矩 Output torque Nm	传动比 Ratio i	使用系数 Service factor f _s	机型号 Type Type	极数 Pole p
0.25kW						0.37kW					
5.2	430	123.54	1.8	K 67	8	0.19	16930	7483	0.72		
6.0	376	108.03	2.1	KF 67	8	0.21	14853	6565	0.82		
6.3	357	102.62	2.2	KA 67	8	0.24	13131	5804	0.93	K 127R77	4
7.2	313	90.04	2.5	KAF67	8	0.28	11373	5027	1.07	KF 127R77	4
5.9	382	144.79	2.0	K 67	6	0.31	10007	4423	1.22	KA 127R77	4
6.9	326	123.54	2.4	KF 67	6	0.37	8600	3801	1.42	KAF127R77	4
7.9	285	108.03	2.7	KA 67	6	0.43	7324	3237	1.67		
8.3	271	102.62	2.8	KAF67	6	0.72	4357	1926	2.80		
9.6	234	144.79	3.3	K 67	4	0.79	3975	1757	3.07		
11	199	123.54	3.9	KF 67	4	0.90	3486	1541	3.51		
13	174	108.03	4.4	KA 67	4	0.37	8500	3757	0.88		
14	166	102.62	4.7	KAF67	4	0.43	7321	3236	1.03		
5.9	383	145.14	1.5	K 57	6	0.48	6491	2869	1.16	K 107R77	4
6.9	327	123.85	1.7	KF 57	6	0.56	5665	2504	1.33	KF 107R77	4
7.8	286	108.29	2.0	KA 57	6	0.63	4984	2203	1.51	KA 107R77	4
8.3	272	102.88	2.1	KAF57	6	0.74	4229	1869	1.78	KAF107R77	4
9.4	238	90.26	2.4			0.82	3821	1689	1.97		
11	202	76.56	2.8			0.91	3468	1533	2.2		
9.6	234	145.14	2.4	K 57	4	1.06	2980	1317	2.5		
11	200	123.85	2.8	KF 57	4	1.21	2602	1150	2.9		
13	175	108.29	3.2	KA 57	4	0.65	4803	2123	0.84		
14	166	102.88	3.4	KAF57	4	0.75	4199	1856	0.96		
15	146	90.26	3.9			0.86	3676	1625	1.10	K 97R57	4
18	124	76.56	4.6			0.97	3235	1430	1.25	KF 97R57	4
6.4	348	131.87	1.08	K 47	6	1.1	2853	1261	1.42	KA 97R57	4
7.0	321	121.48	1.17	KF 47	6	1.3	2493	1102	1.62	KAF97R57	4
8.1	276	104.37	1.36	KA 47	6	1.5	2165	957	1.87		
9.4	240	90.86	1.57	KAF47	6	1.6	1934	855	2.1		
10	225	85.12	1.67			1.9	1681	743	2.4		
11	213	131.87	1.77	K 47	4	2.1	1473	651	2.7		
11	196	121.48	1.92	KF 47	4	2.4	1296	573	3.1		
13	169	104.37	2.2	KA 47	4	1.0	3201	1415	0.79		
15	147	90.86	2.6	KAF47	4	1.1	2781	1229	0.91		
16	137	85.12	2.7			1.3	2439	1078	1.04		
10	221	83.69	0.9	K 37	6	1.5	2152	951	1.18	K 87R57	4
12	192	72.54	1.0	KF 37	6	1.7	1894	837	1.34	KF 87R57	4
13	179	67.80	1.1	KA 37	6	1.9	1643	726	1.55	KA 87R57	4
15	155	58.60	1.2	KAF37	6	2.2	1443	638	1.76	KAF87R57	4
17	131	49.79	1.4			2.5	1272	562	2.0		
13	172	106.38	1.1			2.9	1072	474	2.4		
14	158	97.81	1.2			3.3	964	426	2.6		
17	135	83.69	1.4			3.7	844	373	3.0		
19	117	72.54	1.6			1.7	1844	815	0.79		
21	109	67.80	1.7			2.0	1604	709	0.91		
24	95	58.60	2.0			2.2	1407	622	1.04		
28	80	49.79	2.3			2.5	1249	552	1.17		
31	72	44.46	2.6			2.9	1097	485	1.33		
37	61	37.97	3.1			3.2	968	428	1.50	K 77R37	4
39	57	35.57	3.3			3.9	810	358	1.80	KF 77R37	4
46	48	29.96	3.9	K 37	4	4.3	724	320	2.0	KA 77R37	4
48	47	28.83	4.0	KF 37	4	4.9	640	283	2.3	KAF77R37	4
56	40	24.99	4.7	KA 37	4	5.7	557	246	2.6		
60	38	23.36	4.9	KAF37	4	6.4	489	216	3.0		
69	33	20.19	5.3			7.3	432	191	3.4		
81	28	17.15	6.1			8.2	385	170	3.8		
91	25	15.31	6.7			9.3	339	150	4.3		
106	21	13.08	7.3			3.3	950	420	0.81		
114	20	12.14	7.7			3.9	817	361	0.94		
133	17	10.49	8.9			4.3	731	323	1.05		
156	14	8.91	10			5.1	615	272	1.25	K 67R37	4
175	13	7.96	11			5.8	543	240	1.42	KF 67R37	4
204	11	6.80	13			6.4	491	217	1.57	KA 67R37	4
218	10	6.37	13			7.3	432	191	1.78	KAF67R37	4
						8.4	376	166	2.05		
						9.7	326	144	2.37		
						12	269	119	2.86		





输出转速 Output speed r/min	输出扭矩 Output torque Nm	传动比 Ratio i	使用系数 Service factor f _B	机型号 Type Type	极数 Pole p	输出转速 Output speed r/min	输出扭矩 Output torque Nm	传动比 Ratio i	使用系数 Service factor f _B	机型号 Type Type	极数 Pole p
0.37kW						0.37kW					
5.1	618	273	0.91			8.5	392	104.37	0.96	K 47	6
5.8	543	240	1.04			9.7	341	90.86	1.10	KF 47	6
6.5	486	215	1.16	K 57R37	4	10	319	85.12	1.18	KA 47	6
7.2	434	192	1.30	KF 57R37	4	12	282	75.2	1.33	KAF47	6
8.4	376	166	1.50	KA 57R37	4	11	315	131.87	1.19		
9.9	319	141	1.77	KAF57R37	4	12	290	121.48	1.30	K 47	4
11	285	126	1.98			13	249	104.37	1.51	KF 47	4
13	244	108	2.3			15	217	90.86	1.73	KA 47	4
15	215	95	2.6			16	203	85.12	1.85	KAF47	4
3.8	868	174.99	2.9	K 87	8	18	180	75.20	2.1		
4.1	813	164.05	3.1	KF 87	8	20	167	69.84	2.3		
4.6	729	147.09	3.5	KA 87	8	22	151	63.30	2.5		
				KAF87	8	14	234	97.81	0.80		
4.5	740	197.27	3.4	K 87	6	17	200	83.69	0.94		
5.1	657	174.99	3.9	KF 87	6	19	173	72.54	1.08		
				KA 87	6	21	162	67.80	1.16		
				KAF87	6	24	140	58.60	1.34		
5.0	671	135.28	2.2	K 77	8	28	119	49.79	1.58		
5.2	637	128.52	2.3	KF 77	8	31	106	44.46	1.77		
5.9	563	113.56	2.6	KA 77	8	37	91	37.97	2.07		
6.9	481	97.05	3.0	KAF77	8	39	85	35.57	2.21		
5.7	578	154.02	2.5	K 77	6	46	72	29.96	2.63	K 37	4
6.5	508	135.28	2.9	KF 77	6	48	69	28.83	2.73	KF 37	4
6.9	482	128.52	3.0	KA 77	6	56	60	24.99	3.15	KA 37	4
7.8	426	113.56	3.4	KAF77	6	60	56	23.36	3.28	KAF37	4
7.23	459	192.18	3.2	K 77	4	69	48	20.19	3.60		
7.75	429	179.37	3.4	KF 77	4	81	41	17.15	4.13		
9.02	368	154.02	4.0	KA 77	4	91	37	15.31	4.5		
				KAF77	4	106	31	13.08	5.0		
6.2	536	108.03	1.44	K 67	8	114	29	12.14	5.2		
6.5	509	102.62	1.52	KF 67	8	133	25	10.49	6.0		
7.4	446	90.04	1.73	KA 67	8	156	21	8.91	7.1		
				KAF67	8	175	19	7.96	7.7		
7.2	464	123.54	1.66	K 67	6	204	16	6.80	8.7		
8.2	405	108.03	1.90	KF 67	6	218	15	6.37	9.0		
8.6	385	102.62	2.0	KA 67	6	259	13	5.56	10		
9.8	338	90.04	2.3	KAF67	6						
9.6	346	144.79	2.2	K 67	4	0.55kW					
11	295	123.54	2.6	KF 67	4	0.08	57099	16978	0.82		
13	258	108.03	3.0	KA 67	4	0.10	47998	14272	0.98	K 187R97	4
15	215	90.04	3.6	KAF67	4	0.11	44111	13116	1.07	KA 187R97	4
18	182	76.37	4.2			0.12	39170	11647	1.20		
7.1	465	123.85	1.2			0.19	24662	7333	1.9		
8.2	406	108.29	1.4	K 57	6	0.12	38783	11532	0.78		
8.6	386	102.88	1.5	KF 57	6	0.14	34395	10227	0.87	K 167R97	4
10	339	90.26	1.7	KA 57	6	0.16	28913	8597	1.04	KA 167R97	4
12	287	76.56	2.0	KAF57	6	0.21	21988	6538	1.37		
13	259	69.12	2.2			0.26	18046	5366	1.67		
9.6	347	145.14	1.6			0.34	13651	4059	2.2		
11	296	123.85	1.9	K 57	4	0.20	23142	6881	0.73	K 157R97	4
13	259	108.29	2.2	KF 57	4	0.23	19947	5931	0.85	KF 157R97	4
14	246	102.88	2.3	KA 57	4	0.35	13365	3974	1.27	KA 157R97	4
15	216	90.26	2.6	KAF57	4	0.46	10247	3047	1.65	KAF157R97	4
18	183	76.56	3.1			0.31	14875	4423	0.82		
20	165	69.12	3.4			0.37	12783	3801	0.96		
						0.43	10886	3237	1.12		
						0.47	9891	2941	1.24	K 127R77	4
						0.55	8569	2548	1.43	KF 127R77	4
						0.72	6477	1926	1.89	KA 127R77	4
						0.79	5909	1757	2.1	KAF127R77	4
						0.90	5183	1541	2.4		
						1.0	4513	1342	2.7		
						1.2	3958	1177	3.1		
						1.4	3447	1025	3.5		

K



输出转速 Output speed r/min	输出扭矩 Output torque Nm	传动比 Ratio i	使用系数 Service factor f _s	机 型 号 Type Type	极 数 Pole p	输出转速 Output speed r/min	输出扭矩 Output torque Nm	传动比 Ratio i	使用系数 Service factor f _s	机 型 号 Type Type	极 数 Pole p
0.55kW						0.55kW					
0.48	9649	2869	0.78			3.8	1290	174.99	2.0	K 87	8
0.56	8421	2504	0.89			4.1	1209	164.05	2.1	KF 87	8
0.63	7409	2203	1.01			4.5	1084	147.09	2.3	KA 87	8
0.74	6286	1869	1.20	K 107R77	4					KAF87	8
0.82	5680	1689	1.32	KF 107R77	4	4.5	1101	197.27	2.3	K 87	6
0.91	5156	1533	1.46	KA 107R77	4	5.1	976	174.99	2.6	KF 87	6
1.1	4429	1317	1.70	KAF107R77	4	5.4	915	164.05	2.8	KA 87	6
1.2	3868	1150	1.94			6.0	821	147.09	3.1	KAF87	6
1.4	3414	1015	2.2			6.5	755	135.28	1.9	K 77	8
1.6	2929	871	2.6			6.9	717	128.52	2.0	KF 77	8
1.8	2630	782	2.9			7.8	634	113.56	2.3	KA 77	8
2.0	2307	686	3.3			9.1	541	97.05	2.7	KAF77	8
2.3	2038	606	3.7								
1.0	4809	1430	0.8			5.7	859	154.02	1.70	K 77	6
1.1	4241	1261	1.0			6.5	755	135.28	1.93	KF 77	6
1.3	3706	1102	1.1			6.9	717	128.52	2.0	KA 77	6
1.5	3218	957	1.3			7.8	634	113.56	2.3	KAF77	6
1.6	2875	855	1.4	K 97R57	4						
1.9	2499	743	1.6	KF 97R57	4	9.0	547	154.02	2.7	K 77	4
2.1	2189	651	1.8	KA 97R57	4	10	481	135.28	3.0	KF 77	4
2.4	1927	573	2.1	KAF97R57	4	11	457	128.52	3.2	KA 77	4
2.8	1695	504	2.4			12	403	113.56	3.6	KAF77	4
3.2	1470	437	2.8			14	345	97.05	4.2		
3.6	1285	382	3.1								
4.6	1026	305	3.9			7.2	689	123.54	1.12	K 67	6
1.5	3198	951	0.79			8.2	603	108.03	1.28	KF 67	6
1.7	2815	837	0.90			8.6	573	102.62	1.35	KA 67	6
1.9	2442	726	1.04			10	502	90.04	1.53	KAF67	6
2.2	2146	638	1.18			12	426	76.37	1.81		
2.5	1890	562	1.34	K 87R57	4						
2.9	1594	474	1.59	KF 87R57	4	11	439	123.54	1.76	K 67	4
3.3	1433	426	1.77	KA 87R57	4	13	384	108.03	2.0	KF 67	4
3.7	1254	373	2.0	KAF87R57	4	15	320	90.04	2.4	KA 67	4
4.2	1110	330	2.3			18	271	76.37	2.8	KAF67	4
4.7	985	293	2.6								
5.6	841	250	3.0			8.2	604	108.29	0.93		
5.9	794	236	3.2			8.6	574	102.88	0.98	K 57	6
6.9	676	201	3.8			9.8	504	90.26	1.12	KF 57	6
						12	427	76.56	1.32	KA 57	6
						13	386	69.12	1.46	KAF57	6
						14	339	60.81	1.66		
						15	320	57.42	1.76		
2.5	1856	552	0.78								
2.9	1631	485	0.89			11	440	123.85	1.28	K 57	4
3.2	1439	428	1.01	K 77R37	4	13	385	108.29	1.47	KF 57	4
3.9	1204	358	1.21	KF 77R37	4	14	365	102.88	1.54	KA 57	4
4.3	1076	320	1.35	KA 77R37	4	15	321	90.26	1.76	KAF57	4
4.9	952	283	1.53	KAF77R37	4	18	272	76.56	2.1		
5.7	827	246	1.76			20	246	69.12	2.3		
6.4	726	216	2.0			23	216	60.81	2.6		
7.3	642	191	2.3			24	204	57.42	2.8		
8.2	572	170	2.5								
9.3	504	150	2.9			13	371	104.37	1.01		
						15	323	90.86	1.17		
5.1	915	272	0.84			16	302	85.12	1.24		
5.8	807	240	0.95	K 67R37	4	18	267	75.20	1.41	K 47	4
6.4	730	217	1.1	KF 67R37	4	20	248	69.84	1.52	KF 47	4
7.3	642	191	1.2	KA 67R37	4	22	225	63.30	1.67	KA 47	4
8.4	558	166	1.4	KAF67R37	4	24	202	56.83	1.86	KAF47	4
9.7	484	144	1.6			28	174	48.95	2.2		
12	400	119	1.9			30	164	46.03	2.3		
7.2	646	192	0.87			24	208	58.6	0.90	K 37	4
8.4	558	166	1.0	K 57R37	4	28	177	49.79	1.06	KF 37	4
9.9	474	141	1.2	KF 57R37	4	31	158	44.46	1.19	KA 37	4
11	424	126	1.3	KA 57R37	4	37	135	37.97	1.39	KAF37	4
13	363	108	1.6	KAF57R37	4						
15	319	95	1.8								





输出转速 Output speed r/min	输出扭矩 Output torque Nm	传动比 Ratio i	使用系数 Service factor f _B	机型号 Type Type	极数 Pole p	输出转速 Output speed r/min	输出扭矩 Output torque Nm	传动比 Ratio i	使用系数 Service factor f _B	机型号 Type Type	极数 Pole p
0.55kW						0.75kW					
39	126	35.57	1.49			1.9	3329	726	0.76		
46	106	29.96	1.77			2.2	2926	638	0.87		
48	102	28.83	1.84			2.5	2577	562	0.98		
56	89	24.99	2.1	K 37	4	2.9	2174	474	1.17	K 87R57	4
60	83	23.36	2.2	KF 37	4	3.3	1954	426	1.30	KF 87R57	4
69	72	20.19	2.4	KA 37	4	3.7	1711	373	1.48	KA 87R57	4
81	61	17.15	2.8	KAF37	4	4.2	1513	330	1.68	KAF87R57	4
91	54	15.31	3.0			4.7	1344	293	1.89		
106	46	13.08	3.3			5.6	1147	250	2.2		
114	43	12.14	3.5			5.9	1082	236	2.3		
133	37	10.49	4.0			6.9	922	201	2.8		
156	32	8.91	4.8								
175	28	7.96	5.2			3.9	1642	358	0.89	K 77R37	4
204	24	6.80	5.8			4.3	1468	320	0.99	KF 77R37	4
218	23	6.37	6.0			4.9	1298	283	1.12	KA 77R37	4
259	19	5.36	6.9			5.7	1128	246	1.29	KA 77R37	4
						6.4	991	216	1.47	KAF77R37	4
0.75kW						0.75kW					
0.11	60151	13116	0.78			3.9	1737	175.47	2.3	K 97	8
0.12	53414	11647	0.88	K 187R97	4	4.4	1508	152.31	2.7	KF 97	8
0.19	33630	7333	1.40	KA 187R97	4	4.8	1389	140.28	2.9	KA 97	8
0.21	30901	6738	1.52								
0.23	27443	5984	1.71								
0.16	39426	8597	0.76			4.6	1456	147.09	1.7	K 87	8
0.21	29984	6538	1.00	K 167R97	4	5.4	1254	126.68	2.0	KF 87	8
0.26	24609	5366	1.22	KA 167R97	4	5.9	1140	115.16	2.2	KA 87	8
0.34	18615	4059	1.62			6.6	1017	102.71	2.5	KAF87	8
0.41	15405	3359	1.95								
0.35	18225	3974	0.93	K 157R97	4	5.2	1295	174.99	2.0	K 87	6
0.46	13974	3047	1.21	KF 157R97	4	5.5	1214	164.05	2.1	KF 87	6
0.83	7705	1680	2.2	KA 157R97	4	6.2	1088	147.09	2.3	KA 87	6
1.02	6260	1365	2.7	KAF157R97	4	7.2	937	126.68	2.7	KAF87	6
0.43	14845	3237	0.82			7.0	956	197.27	2.7	K 87	4
0.47	13488	2941	0.91			8.0	848	174.99	3.0	KF 87	4
0.55	11685	2548	1.05			8.5	795	164.05	3.2	KA 87	4
0.72	8833	1926	1.38	K 127R77	4	9.4	712	147.09	3.6	KAF87	4
0.79	8058	1757	1.52	KF 127R77	4						
0.90	7067	1541	1.73	KA 127R77	4	6.7	1001	135.28	1.46	K 77	6
1.0	6154	1342	1.99	KAF127R77	4	7.1	951	128.52	1.53	KF 77	6
1.2	5398	1177	2.3			8.0	840	113.56	1.73	KA 77	6
1.4	4701	1025	2.6			9.4	718	97.05	2.0	KA 77	6
1.5	4123	899	3.0			10	658	88.97	2.2	KAF77	6
0.82	7746	1689	0.97								
0.91	7030	1533	1.07			9.0	746	154.02	1.95	K 77	4
1.1	6040	1317	1.25			10	655	135.28	2.2	KF 77	4
1.2	5274	1150	1.43	K 107R77	4	11	623	128.52	2.3	KA 77	4
1.4	4655	1015	1.62	KF 107R77	4	12	550	113.56	2.6	KA 77	4
1.6	3994	871	1.88	KA 107R77	4	14	470	97.05	3.1	KAF77	4
1.8	3586	782	2.1	KAF107R77	4						
2.0	3146	686	2.4			11	598	123.54	1.29		
2.3	2779	606	2.7			13	523	108.03	1.47	K 67	4
1.3	5054	1102	0.8			15	436	90.04	1.77	KF 67	4
1.5	4389	957	0.9			18	370	76.37	2.1	KA 67	4
1.6	3921	855	1.0			20	334	68.95	2.3	KA 67	4
1.9	3407	743	1.2			23	294	60.66	2.6	KAF67	4
2.1	2986	651	1.4	K 97R57	4	24	277	57.28	2.8		
2.4	2628	573	1.5	KF 97R57	4						
2.8	2311	504	1.7	KA 97R57	4	11	600	123.85	0.9		
3.2	2004	437	2.0	KAF97R57	4	13	525	108.29	1.1	K 57	4
3.6	1752	382	2.3			14	498	102.88	1.1	KF 57	4
4.6	1399	305	2.9			15	437	90.26	1.3	KA 57	4
5.4	1183	258	3.4			18	371	76.56	1.5	KA 57	4
6.0	1064	232	3.8			20	335	69.12	1.7	KAF57	4
7.0	913	199	4.4			23	295	60.81	1.9		
						24	278	57.42	2.0		
						28	237	48.89	2.4		
						31	215	44.43	2.6		

K



输出转速 Output speed r/min	输出扭矩 Output torque Nm	传动比 Ratio i	使用系数 Service factor f _s	机 型 号 Type Type	极 数 Pole p	输出转速 Output speed r/min	输出扭矩 Output torque Nm	传动比 Ratio i	使用系数 Service factor f _s	机 型 号 Type Type	极 数 Pole p
0.75kW						1.1kW					
18	364	75.2	1.03			1.5	6047	899	2.0		
20	338	69.84	1.11			1.8	5314	790	2.3	K 127R77	4
22	307	63.30	1.23	K 47	4	2.0	4641	690	2.6	KF 127R77	4
24	275	56.83	1.37	KF 47	4	2.3	4029	599	3.0	KA 127R77	4
28	237	48.95	1.59	KA 47	4	2.6	3625	539	3.4	KAF127R77	4
30	223	46.03	1.69	KAF47	4	3.0	3148	468	3.9		
35	192	39.61	1.96			1.2	7735	1150	1.0		
39	171	35.39	2.2			1.4	6827	1015	1.1		
45	151	31.19	2.5			1.6	5859	871	1.3	K 107R77	4
						1.8	5260	782	1.4	KF 107R77	4
31	215	44.46	0.87			2.0	4614	686	1.6	KA 107R77	4
37	184	37.97	1.02			2.3	4076	606	1.8	KAF107R77	4
39	172	35.57	1.09			2.7	3464	515	2.2		
46	145	29.96	1.30			3.1	3060	455	2.5		
48	140	28.83	1.35			3.5	2704	402	2.8		
56	121	24.99	1.55			4.0	2361	351	3.2		
60	113	23.36	1.62			4.5	2065	307	3.6		
69	98	20.19	1.78	K 37	4	1.9	4998	743	0.81		
81	83	17.15	2.0	KF 37	4	2.1	4379	651	0.92	K 97R57	4
91	74	15.31	2.2	KA 37	4	2.4	3854	573	1.05	KF 97R57	4
106	63	13.08	2.4	KAF37	4	2.8	3390	504	1.19	KA 97R57	4
114	59	12.14	2.6			3.2	2939	437	1.38	KAF97R57	4
133	51	10.49	3.0			3.6	2569	382	1.57		
156	43	8.91	3.5			4.1	2300	342	1.76		
175	39	7.96	3.8			2.9	3188	474	0.80		
204	33	6.80	4.3			3.3	2865	426	0.89		
218	31	6.37	4.4			3.7	2509	373	1.01	K 87R57	4
259	26	5.36	5.1			4.2	2220	330	1.14	KF 87R57	4
						4.7	1971	293	1.29	KA 87R57	4
						5.6	1682	250	1.51	KAF87R57	4
						5.9	1587	236	1.60		
						6.9	1352	201	1.88		
						3.9	2548	175.47	1.6	K 97	8
						4.4	2212	152.31	1.8	KF 97	8
						4.8	2037	140.28	2.0	KA 97	8
						5.5	1810	124.61	2.2	KAF97	8
						5.2	1904	175.47	2.1	K 97	6
						5.9	1653	152.31	2.4	KF 97	6
						6.5	1522	140.28	2.7	KA 97	6
						7.3	1352	124.61	3.0	KAF97	6
						8.0	1238	175.47	3.3	K 97	4
						9.1	1074	152.31	3.7	KF 97	4
						10	989	140.28	4.1	KA 97	4
										KAF97	4
						5.2	1899	174.99	1.34	K 87	6
						5.5	1780	164.05	1.42	KF 87	6
						6.2	1596	147.09	1.59	KA 87	6
						7.2	1375	126.68	1.84	KAF87	6
						8.0	1234	174.99	2.1	K 87	4
						8.5	1157	164.05	2.2	KF 87	4
						9.5	1037	147.09	2.4	KA 87	4
						11	894	126.68	2.8	KAF87	4
						12	812	115.16	3.1		
						6.7	1468	135.28	0.99	K 77	6
						7.1	1395	128.52	1.04	KF 77	6
						8.0	1232	113.56	1.18	KA 77	6
						9.4	1053	97.05	1.38	KAF77	6
0.72	12955	1926	0.9								
0.79	11818	1757	1.0	K 127R77	4						
0.90	10365	1541	1.2	KF 127R77	4						
1.0	9027	1342	1.4	KA 127R77	4						
1.2	7917	1177	1.5	KAF127R77	4						
1.4	6894	1025	1.8								





输出转速 Output speed r/min	输出扭矩 Output torque Nm	传动比 Ratio i	使用系数 Service factor f _s	机型号 Type Type	极数 Pole p	输出转速 Output speed r/min	输出扭矩 Output torque Nm	传动比 Ratio i	使用系数 Service factor f _s	机型号 Type Type	极数 Pole p
1.1kW						1.5kW					
10	954	135.28	1.53			0.21	61360	6738	0.77		
11	906	128.52	1.61	K 77	4	0.23	54494	5984	0.86		
12	801	113.56	1.82	KF 77	4	0.26	48720	5350	0.96		
14	685	97.05	2.1	KA 77	4	0.29	43803	4810	1.07	K 187R97	4
16	628	88.97	2.3	KAF77	4	0.32	39741	4364	1.18	KA 187R97	4
18	551	78.07	2.6			0.39	32866	3609	1.43		
19	522	73.99	2.8			0.46	27884	3062	1.69		
13	762	108.03	1.01			0.56	22940	2519	2.0		
14	724	102.62	1.06			0.62	20654	2268	2.3		
16	635	90.04	1.21			0.34	36964	4059	0.81		
18	539	76.37	1.43	K 67	4	0.42	30589	3359	0.98		
20	486	68.95	1.58	KF 67	4	0.51	24961	2741	1.21	K 167R97	4
23	428	60.66	1.80	KA 67	4	0.64	19798	2174	1.52	KA 167R97	4
24	404	57.28	1.91	KAF67	4	0.82	15463	1698	1.95		
29	344	48.77	2.2			1.0	12767	1402	2.4		
32	313	44.32	2.5			1.1	11757	1291	2.6		
36	271	38.39	2.8			0.6	21118	2319	0.8		
16	637	90.26	0.89			0.8	15299	1680	1.1		
18	540	76.56	1.04			1.0	12431	1365	1.4	K 157R97	4
20	488	69.12	1.16			1.1	11192	1229	1.5	KF 157R97	4
23	429	60.81	1.31			1.3	9954	1093	1.7	KA 157R97	4
24	405	57.42	1.39			1.5	8578	942	2.0	KAF157R97	4
29	345	48.89	1.64			1.6	7777	854	2.2		
32	313	44.43	1.80			2.5	5145	565	3.3		
36	271	38.49	2.1			2.8	4581	503	3.7		
39	252	35.70	2.2			2.6	4881	536	2.5	K 127R87	4
46	214	30.28	2.6			3.3	3807	418	3.2	KF 127R87	4
51	193	27.34	2.9	K 57	4	3.8	3342	367	3.7	KA 127R87	4
58	170	24.05	3.3	KF 57	4					KAF127R87	4
62	160	22.71	3.5	KA 57	4	0.80	16000	1757	0.76		
72	136	19.34	4.0	KAF57	4	0.91	14033	1541	0.87		
80	124	17.57	4.2			1.0	12221	1342	1.00		
92	107	15.22	4.6			1.2	10718	1177	1.14	K 127R77	4
106	93	13.25	4.7			1.4	9334	1025	1.31	KF 127R77	4
117	84	11.92	4.9			1.6	8187	899	1.49	KA 127R77	4
124	79	11.26	5.1			1.8	7194	790	1.70	KAF127R77	4
146	68	9.59	5.6			2.0	6284	690	1.94		
161	61	8.71	6.0			2.3	5455	599	2.2		
185	53	7.55	6.4			2.6	4908	539	2.5		
213	46	6.57	7.0			3.0	4262	468	2.9		
25	401	56.83	0.94			3.4	3734	410	3.3		
29	345	48.95	1.09			1.4	9243	1015	0.8		
30	325	46.03	1.16			1.6	7932	871	0.9		
35	279	39.61	1.35	K 47	4	1.8	7121	782	1.1		
40	250	35.39	1.51	KF 47	4	2.0	6247	686	1.2	K 107R77	4
45	220	31.19	1.71	KA 47	4	2.3	5519	606	1.4	KF 107R77	4
48	207	29.32	1.82	KAF47	4	2.7	4690	515	1.6	KA 107R77	4
54	183	25.91	2.1			3.1	4144	455	1.8	KAF107R77	4
64	154	21.81	2.4			3.5	3661	402	2.1		
72	138	19.58	2.7			4.0	3196	351	2.4		
47	211	29.96	0.89			4.6	2796	307	2.7		
56	176	24.99	1.07			2.4	5218	573	0.8		
60	165	23.36	1.11			2.8	4590	504	0.9		
69	142	20.19	1.22			3.2	3980	437	1.0		
82	121	17.15	1.40	K 37	4	3.7	3479	382	1.2	K 97R57	4
91	108	15.31	1.52	KF 37	4	4.1	3114	342	1.3	KF 97R57	4
107	92	13.08	1.68	KA 37	4	4.6	2778	305	1.5	KA 97R57	4
115	86	12.14	1.76	KAF37	4	5.4	2350	258	1.7	KAF97R57	4
133	74	10.49	2.0			6.0	2113	232	1.9		
157	63	8.91	2.4			7.0	1812	199	2.2		
176	56	7.96	2.6								
206	48	6.80	2.9								
220	45	6.37	3.0								
261	38	5.36	3.5								

K



输出转速 Output speed r/min	输出扭矩 Output torque Nm	传动比 Ratio i	使用系数 Service factor f _B	机 型 号 Type Type	极 数 Pole p	输出转速 Output speed r/min	输出扭矩 Output torque Nm	传动比 Ratio i	使用系数 Service factor f _B	机 型 号 Type Type	极 数 Pole p
1.5kW						1.5kW					
4.2	3005	330	0.84	K 87R57	4	23	585	60.81	0.96		
4.8	2668	293	0.95	KF 87R57	4	24	552	57.42	1.02		
5.6	2277	250	1.11	KA 87R57	4	29	470	48.89	1.20		
5.9	2149	236	1.18	KAF87R57	4	32	427	44.43	1.32	K 57	4
7.0	1830	201	1.39			36	370	38.49	1.52	KF 57	4
7.7	1667	183	1.52			39	343	35.70	1.64	KA 57	4
						46	291	30.28	1.94	KAF57	4
				K 107	8	51	263	27.34	2.1		
4.9	2770	141.93	2.7	KF 107	8	58	231	24.05	2.4		
5.8	2334	119.58	3.2	KA 107	8	62	218	22.71	2.6		
6.2	2163	110.83	3.5	KAF107	8	72	186	19.34	2.9		
4.5	2972	152.31	1.36	K 97	8	35	381	39.61	0.99		
4.9	2738	140.28	1.48	KF 97	8	40	340	35.39	1.10		
5.5	2432	124.61	1.66	KA 97	8	45	300	31.19	1.25		
				KAF97	8	48	282	29.32	1.33		
						54	249	25.91	1.51	K 47	4
5.2	2569	175.47	1.57	K 97	6	64	210	21.81	1.79	KF 47	4
6.0	2229	152.31	1.81	KF 97	6	72	188	19.58	2.0	KA 47	4
6.6	2053	140.28	1.97	KA 97	6	83	162	16.86	2.2	KAF47	4
7.4	1824	124.61	2.2	KAF97	6	88	153	15.86	2.3		
						103	131	13.65	2.6		
8.0	1688	175.47	2.4	K 97	4	115	117	12.19	2.8		
9.2	1465	152.31	2.7	KF 97	4	119	113	11.77	2.3		
10	1349	140.28	3.0	KA 97	4						
11	1199	124.61	3.4	KAF97	4						
6.3	2153	147.09	1.18	K 87	6	60	225	23.36	0.82		
7.2	1854	126.68	1.37	KF 87	6	69	194	20.19	0.90		
7.9	1686	115.16	1.50	KA 87	6	82	165	17.15	1.03		
9.0	1503	102.71	1.69	KAF87	6	91	147	15.31	1.12	K 37	4
						107	126	13.08	1.23	KF 37	4
						115	117	12.14	1.29	KA 37	4
8.0	1683	174.99	1.51			133	101	10.49	1.49	KAF37	4
8.5	1578	164.05	1.61	K 87	4	157	86	8.91	1.75		
9.5	1415	147.09	1.79	KF 87	4	176	77	7.96	1.90		
11	1218	126.68	2.1	KA 87	4	206	65	6.80	2.2		
12	1108	115.16	2.3	KAF87	4	220	61	6.37	2.2		
14	988	102.71	2.6			261	52	5.36	2.6		
16	830	86.34	3.1								
8.0	1680	113.56	0.87	K 77	6	2.2kW					
9.4	1436	97.05	1.01	KF 77	6	0.33	57466	4364	0.82		
10	1317	88.97	1.11	KA 77	6	0.39	47524	3609	0.99		
12	1155	78.07	1.26	KAF77	6	0.46	40321	3062	1.17		
						0.50	37108	2818	1.27		
10	1301	135.28	1.12			0.56	33171	2519	1.42	K 187R97	4
11	1236	128.52	1.18			0.63	29866	2268	1.57	KA 187R97	4
12	1092	113.56	1.33			0.69	27048	2054	1.74		
14	933	97.05	1.56			0.78	23979	1821	1.96		
16	856	88.97	1.70	K 77	4	0.88	21135	1605	2.2		
18	751	78.07	1.94	KF 77	4						
19	712	73.99	2.0	KA 77	4						
22	623	64.75	2.3	KAF77	4						
24	561	58.34	2.6								
27	492	51.18	3.0			0.52	36094	2741	0.83		
31	434	45.16	3.4			0.63	29655	2252	1.01		
35	385	40.04	3.8			0.65	28628	2174	1.05	K 167R97	4
						0.84	22360	1698	1.35	KA 167R97	4
						1.0	18462	1402	1.63		
16	866	90.04	0.89			1.1	17000	1291	1.77		
18	735	76.37	1.05			1.3	14498	1101	2.1		
20	663	68.95	1.16			1.5	12431	944	2.4		
23	583	60.66	1.32								
24	551	57.28	1.40	K 67	4	0.85	22123	1680	0.76		
29	469	48.77	1.64	KF 67	4	1.0	17975	1365	0.94		
32	426	44.32	1.81	KA 67	4	1.2	16184	1229	1.05	K 157R97	4
36	369	38.39	2.1	KAF67	4	1.3	14393	1093	1.18	KF 157R97	4
39	343	35.62	2.2			1.5	12404	942	1.36	KA 157R97	4
46	291	30.22	2.7			1.7	11246	854	1.50	KAF157R97	4
51	262	27.28	2.9			1.9	9955	756	1.70		
58	231	24.00	3.3								





输出转速 Output speed r/min	输出扭矩 Output torque Nm	传动比 Ratio i	使用系数 Service factor f _B	机型号 Type Type	极数 Pole p	输出转速 Output speed r/min	输出扭矩 Output torque Nm	传动比 Ratio i	使用系数 Service factor f _B	机型号 Type Type	极数 Pole p
2.2kW						2.2kW					
2.6	7058	536	1.73	K 127R87	4	40	490	35.20	3.0	K 77	4
3.0	6229	473	1.96	KF 127R87	4	46	430	30.89	3.4	KF 77	4
3.4	5504	418	2.2	KA 127R87	4	49	407	29.27	3.6	KA 77	4
3.9	4833	367	2.5	KAF127R87	4	55	356	25.62	4.1	KAF77	4
4.3	4346	330	2.8								
1.4	13497	1025	0.91			23	844	60.66	0.91		
1.6	11838	899	1.03			25	797	57.28	0.97		
1.8	10403	790	1.17	K 127R77	4	29	678	48.77	1.14		
2.1	9086	690	1.34	KF 127R77	4	32	616	44.32	1.25		
2.4	7888	599	1.55	KA 127R77	4	37	534	38.39	1.44		
2.6	7098	539	1.72	KAF127R77	4	40	495	35.62	1.56		
3.0	6163	468	1.98			47	420	30.22	1.83		
3.5	5399	410	2.3			52	379	27.28	2.0		
						59	334	24.00	2.3	K 67	4
						63	315	22.66	2.3	KF 67	4
						74	268	19.30	2.7	KA 67	4
						81	244	17.54	2.9	KAF67	4
						93	211	15.19	3.1		
						107	184	13.22	3.4		
						116	170	12.24	2.9		
						136	145	10.42	3.2		
						150	132	9.47	3.4		
						173	114	8.20	3.6		
						199	99	7.14	4.0		
2.3	7980	606	0.94			32	618	44.43	0.91		
2.8	6782	515	1.11			37	535	38.49	1.05		
3.1	5992	455	1.26	K 107R77	4	40	497	35.70	1.14		
3.5	5294	402	1.42	KF 107R77	4	47	421	30.28	1.34		
4.0	4622	351	1.63	KA 107R77	4	52	380	27.34	1.48	K 57	4
4.6	4043	307	1.86	KAF107R77	4	59	334	24.05	1.69	KF 57	4
5.1	3648	277	2.1			63	316	22.71	1.79	KA 57	4
5.8	3200	243	2.4			73	269	19.34	2.0	KAF57	4
						81	244	17.57	2.1		
						93	212	15.22	2.4		
						107	184	13.25	2.3		
						119	166	11.92	2.4		
						126	157	11.26	2.5		
3.7	5030	382	0.80	K 97R57	4	55	360	25.91	1.04		
4.2	4504	342	0.90	KF 97R57	4	65	303	21.81	1.24		
4.7	4016	305	1.01	KA 97R57	4	73	272	19.58	1.38		
5.5	3397	258	1.19	KAF97R57	4	84	234	16.86	1.52	K 47	4
6.1	3055	232	1.32			90	221	15.86	1.62	KF 47	4
7.1	2620	199	1.54			104	190	13.65	1.78	KA 47	4
						116	170	12.19	1.94	KAF47	4
						121	164	11.77	1.61		
						134	147	10.56	1.79		
						156	127	9.10	2.1		
5.0	3948	141.93	1.90	K 107	8	109	182	13.08	0.85		
5.9	3326	119.58	2.3	KF 107	8	135	146	10.49	1.03	K 37	4
6.4	3083	110.83	2.4	KA 107	8	159	124	8.91	1.21	KF 37	4
7.1	2763	99.34	2.7	KAF107	8	178	111	7.96	1.32	KA 37	4
						209	95	6.80	1.49	KAF37	4
						223	89	6.37	1.54		
						265	75	5.36	1.77		
6.1	3200	152.31	1.26	K 97	6						
6.7	2947	140.28	1.37	KF 97	6						
7.5	2618	124.61	1.54	KA 97	6						
14	1443	103.78	2.80	KAF97	6						
8.1	2440	175.47	1.66								
9.3	2118	152.31	1.91	K 97	4						
10	1951	140.28	2.1	KF 97	4						
11	1733	124.61	2.3	KA 97	4						
14	1443	103.78	2.8	KAF97	4						
15	1346	96.80	3.0								
9.7	2046	147.09	1.24								
11	1762	126.68	1.44								
12	1602	115.16	1.58	K 87	4						
14	1428	102.71	1.78	KF 87	4						
16	1201	86.34	2.1	KA 87	4						
18	1103	79.34	2.3	KAF87	4						
20	980	70.46	2.6								
23	876	63.00	2.9								
13	1579	113.56	0.9								
15	1350	97.05	1.08								
16	1237	88.97	1.18								
18	1086	78.07	1.34								
19	1029	73.99	1.42	K 77	4						
22	901	64.75	1.62	KF 77	4						
24	811	58.34	1.80	KA 77	4						
28	712	51.18	2.0	KAF77	4						
31	628	45.16	2.3								
35	557	40.04	2.6								

K



输出转速 Output speed r/min	输出扭矩 Output torque Nm	传动比 Ratio i	使用系数 Service factor f _s	机 型 号 Type Type	极 数 Pole p	输出转速 Output speed r/min	输出扭矩 Output torque Nm	传动比 Ratio i	使用系数 Service factor f _s	机 型 号 Type Type	极 数 Pole p
3.0kW						3.0kW					
0.46	54983	3062	0.85			10	2692	141.93	2.8	K 107	4
0.5	50602	2818	0.93			12	2268	119.58	3.3	KF 107	4
0.56	45233	2519	1.04							KA 107	4
0.63	40726	2268	1.15	K 187R97	4					KAF107	4
0.69	36883	2054	1.27	KA 187R97	4	7.7	3496	124.61	1.16	K 97	6
0.78	32699	1821	1.44			9.3	2911	103.78	1.39	KF 97	6
0.88	28820	1605	1.63			9.9	2716	96.80	1.49	KA 97	6
1.0	25050	1395	1.88			11	2427	86.52	1.67	KAF97	6
1.2	21476	1196	2.2			8.1	3328	175.47	1.21		
0.84	30490	1698	0.99			9.3	2889	152.31	1.40		
1.0	25175	1402	1.2			10	2660	140.28	1.52		
1.1	23182	1291	1.3	K 167R97	4	11	2363	124.61	1.71	K 97	4
1.3	19770	1101	1.52	KF 167R97	4	14	1968	103.78	2.05	KF 97	4
1.5	16951	944	1.77	KA 167R97	4	15	1836	96.80	2.20	KA 97	4
1.7	15137	843	1.99	KAF167R97	4	16	1646	86.52	2.46	KAF97	4
1.9	13593	757	2.2			18	1477	77.89	2.74		
1.2	22069	1229	0.77			20	1338	70.54	3.02		
1.3	19627	1093	0.86			23	1186	62.55	3.41		
1.5	16915	942	1.00	K 157R97	4	25	1072	56.55	3.77		
1.7	15335	854	1.10	KF 157R97	4	9.6	2790	147.09	0.91		
1.9	13575	756	1.25	KA 157R97	4	11	2403	126.68	1.06		
2.5	10146	565	1.67	KAF157R97	4	12	2184	115.16	1.16		
2.8	9032	503	1.87			14	1948	102.71	1.30	K 87	4
2.6	9625	536	1.27			16	1637	86.34	1.55	KF 87	4
3.0	8494	473	1.44			18	1505	79.34	1.69	KA 87	4
3.4	7506	418	1.63	K 127R87	4	20	1336	70.46	1.90	KAF87	4
3.9	6590	367	1.85	KF 127R87	4	23	1195	63.00	2.1		
4.3	5926	330	2.1	KA 127R87	4	25	1074	56.64	2.4		
4.9	5207	290	2.3	KAF127R87	4	29	932	49.16	2.7		
1.8	14186	790	0.86			32	835	44.02	2.9		
2.1	12390	690	0.99	K 127R77	4	39	693	36.52	3.4		
2.4	10756	599	1.14	KF 127R77	4	16	1687	88.97	0.86		
2.6	9679	539	1.26	KA 127R77	4	18	1481	78.07	0.98		
3.0	8404	468	1.45	KAF127R77	4	19	1403	73.99	1.04		
3.5	7362	410	1.66			22	1228	64.75	1.19	K 77	4
3.1	8170	455	0.92			24	1106	58.34	1.32	KF 77	4
3.5	7219	402	1.04			28	971	51.18	1.50	KA 77	4
4.0	6303	351	1.19			31	856	45.16	1.70	KAF77	4
4.6	5513	307	1.36			35	759	40.04	1.92		
5.1	4974	277	1.51	K 107R77	4	40	668	35.20	2.2		
5.8	4363	243	1.72	KF 107R77	4	46	586	30.89	2.5		
6.6	3861	215	1.95	KA 107R77	4	32	841	44.32	0.92		
7.5	3394	189	2.2	KAF107R77	4	37	728	38.39	1.06		
8.5	3017	168	2.5			40	676	35.62	1.14		
9.5	2676	149	2.8			47	573	30.22	1.34		
10	2496	139	3.0			52	517	27.28	1.49		
5.5	4893	258	0.83	K 97R57	4	59	455	24.00	1.65	K 67	4
6.1	4400	232	0.92	KF 97B57	4	63	430	22.66	1.71	KF 67	4
7.1	3774	199	1.07	KA 97R57	4	74	366	19.30	1.95	KA 67	4
				KAF97R57	4	81	333	17.54	2.1	KAF67	4
5.0	5366	141.46	1.40			93	288	15.19	2.3		
5.9	4543	119.76	1.66			107	251	13.22	2.5		
6.4	4204	110.83	1.79	K 107	8	116	232	12.24	2.1		
7.1	3768	99.34	2.0	KF 107	8	136	198	10.42	2.4		
7.9	3402	89.68	2.2	KA 107	8	150	180	9.47	2.5		
				KAF107	8	47	574	30.28	0.98		
6.8	3968	141.46	1.9	K 107	6	52	519	27.34	1.09	K 57	4
8.0	3360	119.76	2.2	KF 107	6	59	456	24.05	1.24	KF 57	4
8.7	3109	110.83	2.4	KA 107	6	63	431	22.71	1.31	KA 57	4
9.7	2787	99.34	2.7	KAF1076	6	73	367	19.34	1.47	KAF57	4
						81	333	17.57	1.57		





输出转速 Output speed r/min	输出扭矩 Output torque Nm	传动比 Ratio i	使用系数 Service factor f _B	机型号 Type Type	极数 Pole p	输出转速 Output speed r/min	输出扭矩 Output torque Nm	传动比 Ratio i	使用系数 Service factor f _B	机型号 Type Type	极数 Pole p
3.0kW						4.0kW					
93	289	15.22	1.74			4.0	8404	351	0.89		
107	251	13.25	1.9	K 57	4	4.6	7350	307	1.02	K 107R77	4
119	226	11.92	1.7	KF 57	4	5.1	6632	277	1.13	KF 107R77	4
126	214	11.26	1.8	KA 57	4	5.8	5818	243	1.29	KA 107R77	4
148	182	9.59	2.1	KAF57	4	6.6	5148	215	1.46	KAF107R77	4
163	165	8.71	2.2			7.5	4525	189	1.66		
188	143	7.55	2.4			8.5	4022	168	1.68		
216	125	6.57	2.6			9.5	3567	149	1.9		
						11	3232	135	2.1		
73	371	19.58	1.01			7.1	5032	199	0.80	K 97R57	4
84	320	16.86	1.12							KF 97R57	4
90	301	15.86	1.19							KA 97R57	4
104	259	13.65	1.31	K 47	4					KAF97R57	4
116	231	12.19	1.42	KF 47	4						
121	223	11.77	1.18	KA 47	4						
134	200	10.56	1.31	KAF47	4						
156	173	9.1	1.53			5.3	6825	134.94	1.8	K 127	8
166	162	8.56	1.56			5.8	6202	122.60	2.0	KF 127	8
193	140	7.36	1.68			6.4	5570	110.13	2.2	KA 127	8
216	125	6.58	1.81							KAF127	8
244	110	5.81	1.96			6.6	5464	146.07	2.2	K 127	6
						7.1	5047	134.94	2.4	KF 127	6
159	169	8.91	0.89	K 37	4	7.8	4587	122.60	2.7	KA 127	6
178	151	7.96	0.97	KF 37	4	8.7	4119	110.13	3.0	KAF127	6
209	129	6.8	1.09	KA 37	4						
223	121	6.37	1.13	KAF37	4	6.4	5605	110.83	1.34	K 107	8
265	102	5.36	1.29			7.1	5024	99.34	1.50	KF 107	8
						7.9	4536	89.68	1.66	KA 107	8
						8.7	4120	81.46	1.83	KAF107	8
4.0kW						6.8	5309	141.93	1.42	K 107	6
1.7	19697	825	2.4	K 187R107	4	8.0	4473	119.58	1.68	KF 107	6
2.8	12272	514	3.8	KA 187R107	4	8.7	4146	110.83	1.81	KA 107	6
						9.7	3716	99.34	2.0	KAF107	6
0.57	59473	2510	0.79			11	3354	89.68	2.2		
0.63	53547	2268	0.88								
0.70	48494	2054	0.97			10	3527	141.46	2.1		
0.79	42993	1821	1.09			12	2986	119.76	2.5		
0.90	37894	1605	1.24	K 187R97	4	13	2764	110.83	2.7	K 107	4
1.0	32936	1395	1.43	KA 187R97	4	14	2477	99.34	3.0	KF 107	4
1.2	28237	1196	1.66			16	2236	89.68	3.4	KA 107	4
1.4	24696	1046	1.90			18	2031	81.46	3.7	KAF107	4
1.5	22240	942	2.1			20	1802	72.27	4.2		
1.0	33101	1402	0.91			10	3498	140.28	1.16		
1.1	30480	1291	0.99			12	3107	124.61	1.30	K 97	4
1.3	25994	1101	1.16			14	2588	103.78	1.56	KF 97	4
1.5	22288	944	1.35	K 167R97	4	15	2414	96.80	1.67	KA 97	4
1.7	19903	843	1.51	KA 167B97	4	17	2157	86.52	1.87	KAF97	4
1.9	17873	757	1.68			18	1942	77.89	2.1		
2.3	14874	630	2.0			20	1759	70.54	2.3		
1.7	20163	854	0.84	K 157R97	4						
1.9	17849	756	0.95	KF 157R97	4						
2.5	13339	565	1.27	KA 157R97	4						
2.9	11876	503	1.42	KAF157R97	4						
3.3	10223	433	1.66			13	2872	115.16	0.88		
						14	2561	102.71	0.99		
						17	2153	86.34	1.18		
2.7	12655	536	0.97			18	1978	79.34	1.28	K 87	4
3.0	11167	473	1.09	K 127R87	4	20	1757	70.46	1.44	KF 87	4
3.4	9869	418	1.24	KF 127R87	4	23	1571	63.00	1.62	KA 87	4
3.9	8665	367	1.41	KA 127R87	4	25	1412	56.64	1.80	KAF87	4
4.3	7901	330	1.55	KAF127R87	4	29	1226	49.16	2.1		
4.9	6943	290	1.76			33	1098	44.02	2.3		
5.6	6057	253	2.0			39	911	36.52	2.8		
2.4	14341	599	0.85	K 127R77	4						
2.6	12905	539	0.95	KF 127R77	4						
3.0	11205	468	1.09	KA 127R77	4						
3.5	9816	410	1.24	KAF127R77	4						

K



输出转速 Output speed r/min	输出扭矩 Output torque Nm	传动比 Ratio i	使用系数 Service factor f _s	机 型 号 Type Type	极 数 Pole p	输出转速 Output speed r/min	输出扭矩 Output torque Nm	传动比 Ratio i	使用系数 Service factor f _s	机 型 号 Type Type	极 数 Pole p
4.0kW						5.5kW					
22	1615	64.75	0.90			3.4	13570	418	0.90		
25	1455	58.34	1.00			3.9	11914	367	1.03		
28	1276	51.18	1.14			4.4	10713	330	1.14	K 127R87	4
32	1126	45.16	1.29	K 77	4	5.0	9414	290	1.30	KF 127R87	4
36	998	40.04	1.46	KF 77	4	5.7	8213	253	1.49	KA 127R87	4
38	957	38.39	1.52	KA 77	4	6.7	6980	215	1.75	KAF127R87	4
41	878	35.20	1.66	KAF77	4	7.1	6590	203	1.71		
47	770	30.89	1.89			8.6	5454	168	2.1		
49	730	29.27	2.0			9.7	4805	148	2.3		
56	639	25.62	2.3			6.7	6980	215	1.08	K 107R77	4
62	576	23.08	2.5			7.6	6136	189	1.23	KF 107R77	4
71	505	20.25	2.9			8.6	5454	168	1.38	KA 107R77	4
						9.7	4837	149	1.55	KAF107R77	4
						11	4383	135	1.72		
48	754	30.22	1.02			4.8	10288	150.03	1.64	K 157	8
53	680	27.28	1.13			5.9	8423	122.83	2.0	KF 157	8
60	598	24.00	1.26			7.2	6833	99.65	2.5	KA 157	8
64	565	22.66	1.30	K 67	4	7.8	6338	92.42	2.7	KAF157	8
75	481	19.30	1.48	KF 67	4						
82	437	17.54	1.59	KA 67	4	5.3	9253	134.94	1.3	K 127	8
95	379	15.19	1.74	KAF67	4	5.9	8399	122.60	1.5	KF 127	8
109	330	13.22	1.91			6.5	7556	110.13	1.6	KA 127	8
118	305	12.24	1.63			8.1	6143	89.43	2.0	KAF127	8
138	260	10.42	1.81								
152	236	9.47	1.91			7.1	6940	134.94	1.76	K 127	6
176	204	8.20	2.02			7.8	6299	122.60	1.94	KF 127	6
202	178	7.14	2.2			8.7	5667	110.13	2.2	KA 127	6
						11	4599	89.43	2.7	KAF127	6
60	600	24.05	0.94			8.7	5700	110.83	1.32	K 107	6
63	566	22.71	1.00			9.7	5109	99.34	1.47	KF 107	6
74	482	19.34	1.12			11	4612	89.68	1.63	KA 107	6
82	438	17.57	1.19	K 57	4	12	4190	81.46	1.79	KAF107	6
95	380	15.22	1.33	KF 57	4						
109	330	13.25	1.45	KA 57	4	10	4866	141.93	1.55		
121	297	11.92	1.31	KAF57	4	12	4100	119.58	1.83	K 107	4
128	281	11.26	1.39			13	3800	110.83	1.98	KF 107	4
150	239	9.59	1.59			14	3406	99.34	2.2	KA 107	4
165	217	8.71	1.69			16	3075	89.68	2.4	KAF107	4
191	188	7.55	1.82			18	2793	81.46	2.7		
219	164	6.57	1.98								
5.5kW											
0.79	59116	1821	0.80			12	4273	124.61	0.95		
0.90	52104	1605	0.90			14	3558	103.78	1.1		
1.0	45286	1395	1.04	K 187R97	4	15	3319	96.80	1.2		
1.2	38826	1196	1.21	KA 187R97	4	17	2967	86.52	1.35	K 97	4
1.4	33957	1046	1.38			18	2671	77.89	1.5	KF 97	4
1.5	30580	942	1.54			20	2419	70.54	1.65	KA 97	4
2.0	23926	737	2.0			23	2145	62.55	1.85	KAF97	4
2.3	20095	619	2.3			25	1939	56.55	2.1		
						30	1643	47.93	2.4		
1.31	35742	1101	0.84								
1.5	30645	944	0.98			17	2960	86.34	0.85		
1.7	27367	843	1.10			18	2720	79.34	0.95		
1.9	24575	757	1.22	K 167R97	4	20	2416	70.46	1.05		
2.3	20452	630	1.47	KA 167R97	4	23	2160	63.00	1.15		
2.6	18212	561	1.65			25	1942	56.64	1.3	K 87	4
3.0	15550	479	1.93			29	1686	49.16	1.5	KF 87	4
3.4	13700	422	2.2			33	1509	44.02	1.6	KA 87	4
						39	1252	36.52	1.85	KAF87	4
2.2	21458	661	0.79			46	1076	31.39	2.3		
2.5	18342	565	0.92	K 157R97	4	52	956	27.88	2.5		
2.9	16329	503	1.04	KF 157R97	4						
3.3	14057	433	1.20	KA 157R97	4	32	1548	45.16	0.94	K 77	4
3.8	12271	378	1.38	KAF157R97	4	36	1373	40.04	1.06	KF 77	4
4.3	10778	332	1.57			47	1059	30.89	1.38	KA 77	4
						49	1004	29.27	1.45	KAF77	4
						56	878	25.62	1.66		





输出转速 Output speed r/min	输出扭矩 Output torque Nm	传动比 Ratio i	使用系数 Service factor f _s	机型号 Type Type	极数 Pole p	输出转速 Output speed r/min	输出扭矩 Output torque Nm	传动比 Ratio i	使用系数 Service factor f _s	机型号 Type Type	极数 Pole p
5.5kW						7.5kW					
62	791	23.08	1.84			6.4	10522	150.03	1.6	K 157	6
71	694	20.25	2.0	K 77	4	7.8	8614	122.83	2.0	KF 157	6
81	613	17.87	2.2	KF 77	4	9.6	6989	99.65	2.4	KA 157	6
91	543	15.84	2.4	KA 77	4	10	6482	92.42	2.6	KAF157	6
107	464	13.52	2.5			12	5593	79.75	3.0		
117	424	12.36	2.6	KAF77	4	7.1	9464	134.94	1.29	K 127	6
133	371	10.81	2.7			7.8	8590	122.48	1.42	KF 127	6
						8.7	7727	110.18	1.58	KA 127	6
60	823	24.00	0.91			11	6272	89.43	1.95	KAF127	6
64	777	22.66	0.94			10	6736	146.07	1.81		
75	662	19.30	1.08			11	6223	134.94	1.96	K 127	4
82	601	17.54	1.16	K 67	4	12	5648	122.60	2.2	KF 127	4
95	521	15.19	1.26	KF 67	4	13	5081	110.13	2.4	KA 127	4
109	453	13.22	1.39	KA 67	4	16	4124	89.43	3.0	KAF127	4
118	420	12.24	1.39			18	3805	82.52	3.2		
138	357	10.42	1.32	KAF67	4	21	3272	70.95	3.7		
152	325	9.47	1.39			10	6545	141.93	1.15		
176	281	8.20	1.47			12	5514	119.58	1.36		
202	245	7.14	1.61			13	5111	110.83	1.47		
						15	4581	99.34	1.64	K 107	4
82	602	17.57	0.87			16	4136	89.68	1.82	KF 107	4
95	522	15.22	0.96	K 57	4	18	3757	81.46	2.00	KA 107	4
109	454	13.25	0.97	KF 57	4	20	3333	72.27	2.3	KAF107	4
121	409	11.92	1.01	KA 57	4	22	3024	65.58	2.5		
128	386	11.26	1.06			26	2599	56.37	2.9		
150	329	9.59	1.16	KAF57	4	30	2269	49.20	3.2		
165	299	8.71	1.23			35	1925	41.74	3.6		
191	259	7.55	1.33			40	1682	36.48	4.0		
219	225	6.57	1.44			15	4464	96.80	0.91		
7.5kW						17	3990	86.52	1.01		
1.8	36021	825	1.30	K 187R107	4	19	3592	77.89	1.13		
2.0	31437	720	1.50	KA 187R107	4	21	3253	70.54	1.24	K 97	4
2.4	26808	614	1.75			23	2884	62.55	1.40	KF 97	4
						26	2608	56.55	1.55	KA 97	4
1.2	52220	1196	0.90			30	2210	47.93	1.83	KAF97	4
1.4	45670	1046	1.03			35	1931	41.87	2.1		
1.5	41129	942	1.14	K 187R97	4	38	1766	38.30	2.3		
2.0	32179	737	1.46	KA 187R97	4	43	1579	34.23	2.6		
2.4	27027	619	1.74			23	2905	63.00	0.87		
2.8	22879	524	2.1			26	2612	56.64	0.97		
						30	2267	49.16	1.12		
1.7	36807	843	0.82			33	2030	44.02	1.20		
1.9	33052	757	0.91			40	1684	36.52	1.40	K 87	4
2.3	27507	630	1.09	K 167R97	4	47	1448	31.39	1.75	KF 87	4
2.6	24494	561	1.23	KF 167R97	4	52	1286	27.88	1.90	KA 87	4
3.0	20914	479	1.44	KA 167R97	4	59	1149	24.92	2.0	KAF87	4
3.5	18425	422	1.63			65	1033	22.41	2.1		
4.0	16024	367	1.88	KAF167R97	4	75	897	19.45	2.4		
						84	803	17.42	2.6		
3.4	18906	433	0.89	K 157R97	4	92	736	15.95	2.3		
3.9	16504	378	1.03	KF 157R97	4	101	666	14.45	3.0		
4.4	14496	332	1.17	KA 157R97	4	47	1424	30.89	1.02		
5.0	12662	290	1.34	KAF157R97	4	50	1350	29.27	1.08		
						57	1181	25.62	1.23		
4.4	14408	330	0.85			63	1064	23.08	1.37	K 77	4
5.0	12662	290	0.97	K 127R87	4	72	934	20.25	1.56	KF 77	4
5.8	11046	253	1.11	KF 127R87	4	82	824	17.87	1.65	KA 77	4
6.8	9387	215	1.30	KA 127R87	4	92	730	15.84	1.80	KAF77	4
7.2	8863	203	1.38			108	623	13.52	1.82		
8.7	7335	168	1.67	KAF127R87	4	118	570	12.36	1.89		
9.9	6462	148	1.89			135	499	10.81	1.95		
						153	440	9.54	2.0		
4.4	15382	164.44	2.0	K 167	8	173	390	8.46	2.1		
5.3	12623	135.38	2.4	KA 167	8	202	333	7.22	2.3		
						5.8	11537	164.44	2.61	K 167	6
7.1	9467	135.38	3.18	KA 167	6						

K



输出转速 Output speed r/min	输出扭矩 Output torque Nm	传动比 Ratio i	使用系数 Service factor f _s	机 型 号 Type Type	极 数 Pole p	输出转速 Output speed r/min	输出扭矩 Output torque Nm	传动比 Ratio i	使用系数 Service factor f _s	机 型 号 Type Type	极 数 Pole p
11kW						11kW					
1.8	52831	825	0.89			20	4888	72.27	1.54		
2.0	46107	720	1.02	K 187R107	4	22	4435	65.58	1.70	K 107	4
2.4	39319	614	1.20	KA 187R107	4	26	3813	56.37	1.97	KF 107	4
2.8	32915	514	1.43			30	3328	49.2	2.2	KA 107	4
3.3	28753	449	1.63			35	2823	41.74	2.5	KAF107	4
4.0	23374	365	2.0			40	2467	36.48	2.7		
2.0	47196	737	1.00	K 187R97	4	21	4771	70.54	0.85		
2.4	39639	619	1.19	KA 187R97	4	23	4231	62.55	0.96		
2.8	33556	524	1.40			26	3825	56.55	1.06	K 97	4
4.7	20044	313	1.50			30	3242	47.93	1.25	KF 97	4
5.3	17482	273	1.72	K 167R107	4	35	2832	41.87	1.43	KA 97	4
5.8	16009	250	1.88	KA 167R107	4	38	2590	38.3	1.56	KAF97	4
6.7	13960	218	2.2			43	2315	34.23	1.75		
7.2	13000	203	2.3			47	2085	30.82	1.94		
2.6	35925	561	0.84			52	1888	27.91	2.1		
3.0	30674	479	0.98	K 167R97	4	59	1674	24.75	2.4		
3.5	27024	422	1.11	KA 167R97	4	65	1513	22.37	2.7		
4.0	23502	367	1.28			33	2977	44.02	0.82		
4.4	21260	332	0.80	K 157R97	4	40	2470	36.52	0.95		
5.0	18571	290	0.91	KF 157R97	4	47	2123	31.39	1.20		
6.8	13768	215	0.89	KA 157R97	4	52	1886	27.88	1.30		
7.2	13000	203	0.94	KAF157R97	4	59	1685	24.92	1.39		
8.7	10758	168	1.14	K 127R87	4	65	1516	22.41	1.43	K 87	4
9.9	9478	148	1.29	KF 127R87	4	75	1315	19.45	1.64	KF 87	4
5.4	18313	135.38	1.64	KA 127R87	4	84	1178	17.42	1.76	KA 87	4
6.6	14932	110.38	2.0	KAF127R87	4	92	1079	15.95	1.57	KAF87	4
5.9	16740	164.44	1.80	K 167	8	101	977	14.45	1.9		
7.2	13782	135.38	2.2	KA 167	8	116	849	12.56	2.0		
8.9	11122	164.44	2.7			131	753	11.13	2.1		
11	9158	135.38	3.3	K 167	6	147	674	9.96	2.2		
5.9	16615	122.83	1.02	KA 167	6	177	559	8.27	2.4		
7.3	13480	99.65	1.26	K 157	8	203	486	7.19	2.5		
7.9	12502	92.42	1.35	KF 157	8	63	1561	23.08	0.93		
9.1	10788	79.75	1.57	KA 157	8	72	1370	20.25	1.03		
6.5	15273	150.03	1.11	K 157	6	82	1209	17.87	1.13		
7.9	12504	122.83	1.35	KF 157	6	88	1071	15.84	1.23	K 77	4
9.7	10144	99.65	1.67	KA 157	6	92	1071	15.84	1.23	KF 77	4
10	9408	92.42	1.80	KAF157	6	108	914	13.52	1.38	KA 77	4
12	8119	79.75	2.1			118	836	12.36	1.12	KA 77	4
9.7	10147	150.03	1.67	K 157	4	135	731	10.81	1.27	KAF77	4
12	8308	122.83	2.0	KF 157	4	153	645	9.54	1.37		
15	6740	99.65	2.5	KA 157	4	173	572	8.46	1.46		
16	6251	92.42	2.7	KAF1574	4	202	488	7.22	1.57		
11	9127	134.94	1.34			15kW					
12	8295	122.60	1.47	K 127	4	2.4	53617	614	0.88		
13	7449	110.13	1.64	KF 127	4	2.8	44884	514	1.05	K 187R107	4
16	6049	89.43	2.0	KA 127	4	3.3	39208	449	1.20	KA 187R107	4
18	5581	82.52	2.2	KAF127	4	4.0	31873	365	1.47		
21	4799	70.95	2.5			5.4	23403	268	2.0		
13	7496	110.83	1.00	K 107	4	4.7	27332	313	1.10		
15	6719	99.34	1.12	KF 107	4	5.3	23839	273	1.26		
16	6066	89.68	1.24	KA 107	4	5.8	21831	250	1.38		
18	5510	81.46	1.36	KAF107	4	6.7	19037	218	1.58	K 167R107	4
						7.2	17727	203	1.70	KA 167R107	4
						7.9	16155	185	1.86		
						9.0	14234	163	2.1		
						6.2	20696	237	0.82	K 157R107	4
						7.0	18338	210	0.92	KF 157R107	4
						7.9	16068	184	1.05	KA 157R107	4
						9.4	13535	155	1.25	KAF157R107	4
						12	11003	126	1.54		
						13	9606	110	1.76		





输出转速 Output speed r/min	输出扭矩 Output torque Nm	传动比 Ratio i	使用系数 Service factor f _B	机型号 Type Type	极数 Pole p	输出转速 Output speed r/min	输出扭矩 Output torque Nm	传动比 Ratio i	使用系数 Service factor f _B	机型号 Type Type	极数 Pole p
15kW						18.5kW					
5.4	25096	180.78	1.87	K 187	6	2.9	54981	514	0.85		
6.0	22285	160.53	2.1	KA 187	6	3.3	48028	449	0.98	K 187R107	4
7.2	18793	135.38	1.60	K 167	6	4.0	39043	365	1.20	KA 187R107	4
8.8	15324	110.39	1.96	KA 167	6	5.5	28667	268	1.64		
8.9	15166	164.44	1.12	K 167	4	6.5	24281	227	1.9		
11	12486	135.38	1.36	KA 167	4	4.7	33481	313	0.90		
7.9	16990	122.39	1.00	K 157	6	5.4	29202	273	1.03		
9.7	13833	99.65	1.22	KF 157	6	5.9	26742	250	1.12	K 167R107	4
10	12830	92.42	1.32	KA 157	6	6.7	23319	218	1.29	KA 167R107	4
12	11071	79.75	1.53	KAF157	6	7.2	21714	203	1.39		
14	9770	70.35	1.73			7.9	19789	185	1.52		
9.7	13837	150.03	1.22	K 157	4	9.0	17436	163	1.73		
12	11329	122.83	1.49	KF 157	4	11	14868	139	2.0		
15	9191	99.65	1.84	KA 157	4	12	12943	121	2.3		
16	8524	92.42	2.0	KAF157	4	8.0	19682	184	0.86	K 157R107	4
18	7355	79.75	2.3			9.5	16580	155	1.02	KF 157R107	4
11	12445	134.94	0.97			12	13478	126	1.26	KA 157R107	4
12	11307	122.60	1.08			13	11766	110	1.44	KAF 157R107	4
13	10157	110.13	1.20	K 127	4	5.4	30951	180.78	1.52		
16	8248	89.43	1.48	KF 127	4	6.0	27484	160.53	1.71		
18	7611	82.52	1.61	KA 127	4	6.7	24745	144.53	1.9	K 187	6
21	6544	70.95	1.87	KAF127	4	7.4	22317	130.35	2.1	KA 187	6
23	5774	62.60	2.1			8.1	20424	180.78	2.3		
27	4987	54.07	2.5			9.2	18136	160.53	2.6	K 187	4
31	4410	47.82	2.8			10	16328	144.53	2.9	KA 187	4
16	8271	89.68	0.91			11	14726	130.35	3.2		
18	7513	81.46	1.00			11	15195	134.5	1.98	K 167	4
20	6665	72.27	1.13			13	12471	110.39	2.4	KA 167	4
22	6048	65.58	1.24	K 107	4	17	9851	87.20	3.1		
26	5199	56.37	1.45	KF 107	4	10	17061	99.65	0.99	K 157	6
30	4538	49.2	1.62	KA 107	4	11	15823	92.42	1.08	KF 157	6
35	3850	41.74	1.80	KAF107	4	12	13654	79.75	1.24	KA 157	6
40	3365	36.48	2.0			14	12050	70.38	1.4	KAF157	6
45	2972	32.22	2.2			12	13827	122.39	1.22		
47	2844	30.84	2.3			15	11258	99.65	1.50		
51	2637	28.59	2.6			16	10441	92.42	1.62	K 157	4
30	4421	47.93	0.91			18	9010	79.75	1.88	KF 157	4
35	3862	41.87	1.05			21	7951	70.38	2.1	KA 157	4
38	3532	38.3	1.14			24	6894	61.02	2.5	KAF157	4
43	3157	34.23	1.28	K 97	4	27	6133	54.29	2.8		
47	2843	30.82	1.42	KF 97	4	31	5286	46.79	3.2		
52	2574	27.91	1.57	KA 97	4	39	4295	38.02	3.9		
59	2283	24.75	1.77	KAF97	4	13	12442	110.13	0.98		
65	2063	22.37	1.96			16	10103	89.43	1.21		
77	1749	18.96	2.3			18	9323	82.52	1.31		
88	1527	16.56	2.6			21	8016	70.95	1.52	K 127	4
47	2895	31.39	0.88			23	7072	62.60	1.73	KF 127	4
52	2571	27.88	0.99			27	6109	54.07	2.0	KA 127	4
59	2298	24.92	1.10			31	5403	47.82	2.3	KAF127	4
65	2067	22.41	1.23			37	4540	40.19	2.7		
75	1794	19.45	1.37	K 87	4	41	4121	36.48	3.0		
84	1607	17.42	1.41	KF 87	4	47	3544	31.36	3.4		
92	1471	15.95	1.48	KA 87	4	53	3127	27.67	3.9		
101	1333	14.45	1.5	KAF87	4	20	8165	72.27	0.92	K 107	4
116	1158	12.56	1.53			22	7409	65.58	1.01	KF 107	4
131	1027	11.13	1.58			26	6368	56.37	1.18	KA 107	4
147	919	9.96	1.73			30	5558	49.2	1.35	KAF107	4
177	763	8.27	1.84			35	4716	41.74	1.47		
203	663	7.19	2.2			40	4121	36.48	1.64		

K



输出转速 Output speed r/min	输出扭矩 Output torque Nm	传动比 Ratio i	使用系数 Service factor f _s	机 型 号 Type Type	极 数 Pole p	输出转速 Output speed r/min	输出扭矩 Output torque Nm	传动比 Ratio i	使用系数 Service factor f _s	机 型 号 Type Type	极 数 Pole p
18.5kW						22kW					
46	3640	32.22	1.86			9.7	20289	99.65	0.83	K 157	6
48	3484	30.84	1.88	K 107	4	11	18817	92.42	0.90	KF 157	6
51	3230	28.59	2.1	KF 107	4	12	16237	79.75	1.04	KA 157	6
57	2931	25.94	2.3	KA 107	4	14	14330	70.38	1.18	KAF157	6
66	2519	22.30	2.7	KAF107	4	16	12424	61.02	1.36		
76	2199	19.46	3.1			12	16502	122.83	1.03		
89	1865	16.51	3.6			15	13388	99.65	1.26		
35	4730	41.87	0.85			16	12417	92.42	1.36	K 157	4
48	3482	30.82	1.16			18	10714	79.75	1.58	KF 157	4
53	3153	27.91	1.28	K 97	4	21	9456	70.38	1.79	KA 157	4
59	2796	24.75	1.45	KF 97	4	24	8198	61.02	2.1	KAF157	4
66	2527	22.37	1.60	KA 97	4	27	7294	54.29	2.3		
78	2142	18.96	1.9	KAF97	4	31	6286	46.79	2.7		
89	1871	16.56	2.2			39	5108	38.02	3.3		
106	1565	13.85	2.6			16	12015	89.43	1.02		
123	1355	11.99	2.7			18	11087	82.52	1.10		
59	2815	24.92	0.83			21	9532	70.95	1.28	K 127	4
66	2532	22.41	0.85			23	8410	62.60	1.45	KF 127	4
76	2197	19.45	0.98			27	7264	54.07	1.68	KA 127	4
84	1968	17.42	1.05	K 87	4	31	6425	47.82	1.90	KAF127	4
102	1633	14.45	1.12	KF 87	4	37	5400	40.19	2.3		
117	1419	12.56	1.21	KA 87	4	40	4901	36.48	2.5		
132	1257	11.13	1.25	KAF87	4	47	4215	31.36	2.9		
148	1125	9.96	1.32			53	3719	27.67	3.3		
178	934	8.27	1.41			61	3212	23.90	3.8		
204	812	7.19	1.50			70	2841	21.14	4.3		
22kW						22kW					
3.3	57114	449	0.82			26	7573	56.37	0.99		
4.0	46429	365	1.01			30	6610	49.20	1.11		
5.5	34091	268	1.38	K 187R107	4	35	5608	41.74	1.23		
6.5	28875	227	1.63	KA 187R107	4	40	4901	36.48	1.38		
7.4	25313	199	1.86			46	4329	32.22	1.56		
8.8	21370	168	2.2			48	4143	30.84	1.54	K 107	4
5.4	34727	273	0.87			51	3841	28.59	1.76	KF 107	4
5.9	31801	250	0.95			57	3485	25.94	1.94	KA 107	4
6.7	27730	218	1.08	K 167R107	4	66	2996	22.30	2.2	KAF107	4
7.2	25822	203	1.16	KA 167R107	4	76	2614	19.46	2.3		
7.9	23533	185	1.28			89	2218	16.51	2.6		
9.0	20734	163	1.45			102	1939	14.43	2.6		
11	17681	139	1.70			109	1815	13.51	2.9		
12	15392	121	2.0			125	1584	11.79	3.0		
9.5	19717	155	0.86	K 157R107	4	147	1343	10	3.3		
12	16028	126	1.06	KF 157R107	4	48	4141	30.82	0.98		
13	13992	110	1.21	KA 157R107	4	53	3750	27.91	1.08		
				KAF157R107	4	59	3325	24.75	1.22	K 97	4
5.4	36807	180.78	1.28			66	3005	22.37	1.34	KF 97	4
6.0	32684	160.53	1.44	K 187	6	78	2547	18.96	1.59	KA 97	4
6.7	29427	144.53	1.60	KA 187	6	89	2225	16.56	1.82	KAF97	4
7.4	26540	130.35	1.77			106	1861	13.85	1.87		
8.6	23044	113.18	2.0			123	1611	11.99	2.1		
8.1	24288	180.78	1.94			137	1439	10.71	2.2		
9.2	21567	160.53	2.2	K 187	4	164	1202	8.95	2.3		
10	19418	144.53	2.4	KA 187	4	76	2613	19.45	0.83		
11	17512	130.35	2.7			84	2340	17.42	0.88	K 87	4
11	18070	134.5	1.66			102	1941	14.45	0.94	KF 87	4
13	14831	110.39	2.0	K 167	4	117	1687	12.56	1.02	KA 87	4
17	11715	87.20	2.6	KA 167	4	132	1495	11.13	1.05	KAF87	4
19	10460	77.86	2.9			148	1338	9.96	1.11		
						178	1111	8.27	1.18		
						204	966	7.19	1.27		





输出转速 Output speed r/min	输出扭矩 Output torque Nm	传动比 Ratio i	使用系数 Service factor f _s	机型号 Type Type	极数 Pole p	输出转速 Output speed r/min	输出扭矩 Output torque Nm	传动比 Ratio i	使用系数 Service factor f _s	机型号 Type Type	极数 Pole p
30kW						37kW					
5.5	49099	268	0.96			5.5	56947	268	0.83		
6.5	41587	227	1.13	K 187R107	4	6.5	48235	227	0.97	K 187R107	4
7.4	36458	199	1.29	KA 187R107	4	7.4	42285	199	1.11	KA 187R107	4
8.8	30778	168	1.5			8.8	35698	168	1.32		
6.7	39938	218	0.75			8.0	39310	185	0.77		
7.2	37190	203	0.81			9.1	34635	163	0.87	K 167R107	4
7.9	33893	185	0.89	K 167R107	4	11	29536	139	1.02	KA 167R107	4
9.0	29862	163	1.01	KA 167R107	4	12	25711	121	1.17		
11	25465	139	1.18			8.2	40572	180.78	1.16		
12	22168	121	1.36			8.9	37268	166.06	1.26		
8.1	33120	180.78	1.42			10	32436	144.53	1.45	K 187	4
8.9	30423	166.06	1.54			11	29395	130.98	1.60	KA 187	4
10	26478	144.53	1.78			13	25400	113.18	1.85		
11	23996	130.98	1.96	K 187	4	14	23046	102.69	2.0		
13	20735	113.18	2.3	KA 187	4	17	19853	88.46	2.4		
14	18813	102.69	2.5			14	24559	109.43	1.22		
17	16206	88.46	2.9			17	19646	87.54	1.53		
13	20048	109.43	1.50			19	17828	78.44	1.69	K 167	4
17	15975	87.20	1.88	K 167	4	22	15301	68.18	2.0	KA 167	4
19	14554	79.44	2.1	KA 167	4	24	13582	60.52	2.2		
22	12427	67.83	2.4			35	9592	42.74	3.1		
24	11088	60.52	2.7			16	20741	92.42	0.82		
15	18256	99.65	0.93			19	17898	79.75	0.95		
16	16932	92.42	1.00			21	15795	70.38	1.07	K 157	4
18	14611	79.75	1.16			24	13694	61.02	1.24	KF 157	4
21	12894	70.38	1.31	K 157	4	27	12184	54.29	1.39	KA 157	4
24	11179	61.02	1.51	KF 157	4	32	10501	46.79	1.61	KAF157	4
27	9946	54.29	1.70	KA 157	4	39	8533	38.02	1.98		
31	8572	46.79	1.97	KAF157	4	47	7025	31.30	2.4		
39	6965	38.02	2.4			24	14049	62.60	0.87		
47	5734	31.30	3.0			27	12135	54.07	1.01		
21	12998	70.95	0.94			31	10732	47.82	1.14		
23	11469	62.60	1.07			37	9020	40.19	1.35		
27	9906	54.07	1.23	K 127	4	41	8187	36.48	1.49		
31	8761	47.82	1.39	KF 127	4	47	7040	31.36	1.74	K 127	4
37	7363	40.19	1.66	KA 127	4	53	6212	27.67	1.97	KF 127	4
40	6683	36.48	1.83	KAF127	4	62	5366	23.90	2.3	KA 127	4
47	5747	31.36	2.1			70	4747	21.14	2.6	KAF127	4
53	5071	27.67	2.4			83	3988	17.77	2.8		
61	4380	23.90	2.8			103	3220	14.35	3.1		
35	7647	41.74	0.90			116	2870	12.78	3.1		
40	6683	36.48	1.01			138	2410	10.74	3.5		
46	5903	32.22	1.08			171	1948	8.68	3.5		
51	5238	28.59	1.29			41	8187	36.48	0.83		
57	4752	25.94	1.42	K 107	4	48	6921	30.84	0.92		
66	4085	22.30	1.63	KF 107	4	52	6416	28.59	1.05		
76	3565	19.46	1.66	KA 107	4	57	5822	25.94	1.16		
89	3025	16.51	1.87	KAF107	4	66	5005	22.3	1.33	K 107	4
102	2644	14.43	1.90			76	4367	19.46	1.35	KF 107	4
109	2475	13.51	2.15			90	3705	16.51	1.53	KA 107	4
125	2160	11.79	2.19			103	3238	14.43	1.55	KAF107	4
147	1832	10.00	2.39			110	3032	13.51	1.75		
168	1601	8.74	2.45			126	2646	11.79	1.79		
59	4534	24.75	0.89			148	2244	10.00	1.82		
66	4098	22.37	0.99			169	1961	8.74	1.95		
78	3474	18.96	1.16	K 97	4						
89	3034	16.56	1.33	KF 97	4						
106	2537	13.85	1.59	KA 97	4						
123	2197	11.99	1.66	KAF97	4						
137	1962	10.71	1.37								
164	1640	8.95	1.52								

K



输出转速 Output speed r/min	输出扭矩 Output torque Nm	传动比 Ratio i	使用系数 Service factor f _s	机型号 Type Type	极数 Pole p	输出转速 Output speed r/min	输出扭矩 Output torque Nm	传动比 Ratio i	使用系数 Service factor f _s	机型号 Type Type	极数 Pole p
45kW						55kW					
6.5	58664	227	0.80			17	29204	87.54	1.03		
7.4	51428	199	0.91	K 187R107	4	19	25974	77.86	1.16		
8.8	43416	168	1.08	KA 187R107	4	22	22745	68.18	1.32	K 167	4
11	35922	139	0.84	K 167R107	4	24	20263	60.74	1.48	KA 167	4
12	31270	121	0.96	KA 167R107	4	29	17207	51.58	1.75		
8.2	49344	180.78	0.95			35	14258	42.74	2.1		
8.9	45326	166.06	1.04			41	12170	36.48	2.5		
10	39449	144.53	1.19			24	20357	61.02	0.83		
11	35751	130.98	1.31	K 187	4	27	18111	54.29	0.93		
13	30892	113.18	1.52	KA 187	4	32	15609	46.79	1.08		
14	28029	102.69	1.68			39	12684	38.02	1.33		
17	24145	88.46	1.9			47	10442	31.30	1.62	K 157	4
20	20291	74.34	2.3			54	9214	27.62	1.84	KF 157	4
14	29869	109.43	1.01			62	7990	23.95	2.1	KA 157	4
17	23894	87.54	1.26			69	7109	21.31	2.4	KAF157	4
19	21683	79.44	1.42			81	6128	18.37	2.8		
22	18610	68.18	1.62	K 167	4	99	4977	14.92	3.4		
24	16519	60.52	1.82	KA 167	4	117	4220	12.65	3.8		
29	14079	51.58	2.1			37	13408	40.19	0.91		
35	11666	42.74	2.6			47	10465	31.36	1.17		
21	19210	70.38	0.88			53	9234	27.67	1.32		
24	16655	61.02	1.02			62	7976	23.90	1.53	K 127	4
27	14818	54.29	1.14			70	7056	21.14	1.73	KF 127	4
32	12771	46.79	1.32	K 157	4	83	5928	17.77	2.06	KA 127	4
39	10378	38.02	1.63	KF 157	4	103	4787	14.35	2.38	KAF127	4
47	8543	31.30	2.0	KA 157	4	116	4267	12.78	1.88		
54	7539	27.62	2.2	KAF157	4	138	3583	10.74	2.1		
62	6537	23.95	2.6			171	2896	8.68	2.3		
69	5817	21.31	2.9			75kW					
81	5014	18.37	3.4			11	59298	130.35	0.79		
31	13052	47.82	0.94			13	52224	114.80	0.90		
37	10970	40.19	1.11			14	47016	103.35	1.00	K 187	4
41	9957	36.48	1.23			17	40242	88.46	1.17	KA 187	4
47	8562	31.36	1.43			20	33818	74.34	1.39		
53	7555	27.67	1.62	K 127	4	23	29283	64.37	1.61		
62	6526	23.90	1.87	KF 127	4	28	24402	53.64	1.9		
70	5773	21.14	2.1	KA 127	4	32	20803	45.73	2.3		
83	4850	17.77	2.3	KAF127	4	19	35420	77.86	0.85		
103	3917	14.35	2.5			22	30857	67.83	0.97		
116	3491	12.78	2.6			24	27531	60.52	1.09		
138	2931	10.74	2.8			29	23496	51.65	1.28	K 167	4
171	2369	8.68	2.9			34	19598	43.08	1.53	KA 167	4
52	7804	28.59	0.87			41	16595	36.48	1.81		
57	7080	25.94	0.96			46	14616	32.13	2.1		
66	6087	22.30	1.10			52	13042	28.67	2.3		
76	5312	19.46	1.11	K 107	4	61	11114	24.43	2.7		
90	4506	16.51	1.26	KF 107	4	39	17296	38.02	0.98		
103	3939	14.43	1.44	KA 107	4	47	14239	31.30	1.19		
110	3688	13.51	1.47	KAF107	4	54	12565	27.62	1.35	K 157	4
126	3218	11.79	1.55			62	10895	23.95	1.55	KF 157	4
148	2729	10.00	1.60			69	9694	21.31	1.75	KA 157	4
169	2386	8.74	1.64			81	8357	18.37	2.0	KAF157	4
10	45904	145.33	1.02			99	6787	14.92	2.5		
11	41371	130.98	1.14			117	5755	12.65	2.9		
13	36261	114.80	1.30	K 187	4	47	14271	31.36	0.86		
14	32436	102.69	1.45	KA 187	4	53	12592	27.67	0.97	K 127	4
17	29511	88.46	1.59			62	10877	23.90	1.12	KF 127	4
20	24800	74.34	1.90			70	9621	21.14	1.27	KA 127	4
23	21474	64.37	2.19			83	8084	17.77	1.36	KA 127	4
						103	6528	14.35	1.51	KAF127	4
						114	5900	12.78	1.54		
						138	4886	10.74	1.72		
						171	3949	8.68	1.74		





输出转速 Output speed r/min	输出扭矩 Output torque Nm	传动比 Ratio i	使用系数 Service factor f _B	机型号 Type Type	极数 Pole p	输出转速 Output speed r/min	输出扭矩 Output torque Nm	传动比 Ratio i	使用系数 Service factor f _B	机型号 Type Type	极数 Pole p
90kW						132kW					
14	56058	102.69	0.84			20	59121	74.34	0.79		
16	51134	93.67	0.92			23	51192	64.37	0.92		
19	42242	77.38	1.11			28	42659	53.64	1.10		
23	35139	64.37	1.34	K 187	4	31	38499	48.41	1.22	K 187	4
28	29282	53.64	1.61	KA 187	4	34	34666	43.59	1.36	KA 187	4
31	26427	48.41	1.8			38	30841	38.78	1.52		
34	23796	43.59	2.0			45	26570	33.41	1.77		
38	21170	38.78	2.2			53	22331	28.08	2.1		
						61	19333	24.31	2.3		
						74	16112	20.26	2.6		
						86	13734	17.27	2.8		
22	37028	67.83	0.81								
24	33038	60.52	0.91			35	33990	42.74	0.88		
29	28157	51.58	1.07			41	29012	36.48	1.04		
35	23332	42.74	1.29	K 167	4	46	25942	32.62	1.16	K 167	4
40	19953	36.55	1.51	KA 167	4	54	22053	27.73	1.36	KA 167	4
45	17807	32.62	1.69			61	19429	24.43	1.55		
52	15651	28.67	1.92			74	16104	20.25	1.87		
61	13336	24.43	2.3			86	13742	17.28	2.2		
73	11054	20.25	2.7								
86	9433	17.28	3.2			62	19047	23.95	0.89	K 157	4
						70	16947	21.31	1.00	KF 157	4
39	20755	38.02	0.82			81	14609	18.37	1.16	KA 157	4
47	17087	31.30	0.99			100	11866	14.92	1.43	KAF157	4
54	15078	27.62	1.12	K 157	4	118	10060	12.65	1.59		
62	13074	23.95	1.29	KF 157	4						
69	11633	21.31	1.45	KA 157	4	160kW					
81	10028	18.37	1.69	KAF157	4	28	51708	53.64	0.91		
99	8145	14.92	2.1			33	44082	45.73	1.07		
117	6906	12.65	2.5			42	34096	35.37	1.38	K 187	4
						47	30693	31.84	1.53	KA 187	4
62	13052	23.90	0.94			61	23434	24.31	1.9		
70	11546	21.14	1.06			74	19530	20.26	2.1		
83	9701	17.77	1.15	K 127	4	86	16648	17.27	2.3		
103	7834	14.35	1.26	KF 127	4						
116	6982	12.78	1.28	KA 127	4	41	35166	36.48	0.86	K 167	4
138	5863	10.74	1.43	KAF127	4	62	23338	24.21	1.29	KA 167	4
171	4738	8.68	1.45			73	19800	20.54	1.52		
						86	16657	17.28	1.81		
110kW											
17	58625	88.46	0.80			81	17708	18.37	0.96	K 157	4
20	49267	74.34	0.95			100	14382	14.92	1.18	KF 157	4
21	46173	69.67	1.02			118	12194	12.65	1.39	KA 157	4
24	41853	63.14	1.12	K 187	4						
33	30307	45.73	1.55	KA 187	4	200kW					
35	28332	42.75	1.66			33	55103	45.73	0.85		
38	26178	39.50	1.80			45	40258	33.41	1.17	K 187	4
42	23441	35.37	2.0			47	38366	31.84	1.23	KA 187	4
53	18610	28.08	2.5			59	30618	25.41	1.54		
						74	24413	20.26	1.69		
29	34184	51.58	0.88			86	20810	17.27	1.87		
35	28325	42.74	1.06								
41	24176	36.48	1.24	K 167	4	61	29437	24.43	1.02	K 167	4
46	21618	32.62	1.39	KA 167	4	73	24750	20.54	1.22	KA 167	4
54	18378	27.73	1.64			86	20906	17.35	1.44		
61	16191	24.43	1.86								
74	13420	20.25	2.2			100	17978	14.92	0.94	K 157	4
86	11452	17.28	2.6			118	15243	12.65	1.05	KF 157	4
										KA 157	4
60	15872	23.95	1.07							KAF157	4
70	14123	21.31	1.20	K 157	4						
81	12174	18.37	1.39	KF 157	4						
100	9888	14.92	1.71	KA 157	4						
118	8384	12.65	2.0	KAF157	4						

K



Mamax Permissible torque Nm	输出转速 Output speed r/min	传动比 Ratio i	机型号 Type Type	功率 Power kW/4p	Mamax Permissible torque Nm	输出转速 Output speed r/min	传动比 Ratio i	机型号 Type Type	功率 Power kW/4p	
200	5.0	279	K 37R17 KF 37R17 KA 37R17 KAF37R17	0.18	1550	1.0	1388	K 77R37 KF 77R37 KA 77R37 KAF77R37	0.25	
	5.2	267				1.1	1218			
	5.9	234				1.3	1053			
	6.8	205				1.5	924			
	7.7	181		1.7		815	0.37			
	8.7	160		2.0		709				
	10	136		2.2		622	0.55			
	11	127		2.5		552				
	13	110		2.9		485	0.75			
	14	96		3.2		428				
400	2.5	552	K 47R37 KF 47R37 KA 47R37 KAF47R37	0.18	2700	4.3	320	K 87R57 KF 87R57 KA 87R57 KAF87R57	0.18	
	2.8	495				4.9	283			
	3.3	416				5.7	246			
	3.7	375				0.34	4037			
	4.3	326		0.39		3609	0.25			
	4.8	289		0.45		3107				
	5.6	250		0.51		2728				
	6.3	219		0.59		2371	0.37			
	7.2	193		0.67		2088				
	8.3	167		0.75		1854	0.55			
9.3	149	K 57R37 KF 57R37 KA 57R37 KAF57R37	0.25	4300	0.84	1658	K 97R57 KF 97R57 KA 97R57 KAF97R57	0.25		
11	128				0.98	1415				
1.5	906				1.1	1229				
1.7	806				1.3	1078			0.37	
2.0	699		1.5		951					
2.3	615		1.7		837	0.55				
2.6	544		1.9		726					
2.9	473		2.2		638	0.75				
3.3	421		2.5		562					
3.8	362		3.0		474	1.1				
4.4	319	3.3	426							
5.1	273	3.8	373	1.5						
5.8	240	4.2	330	2.2						
6.5	215	4.8	293	0.18						
7.2	192	5.6	250							
8.4	166	5.9	236							
9.9	141	7.0	201							
11	126	0.23	6027							
13	108	0.26	5392		0.25					
15	95	0.30	4669							
600	1.5	906	K 67R37 KF 67R37 KA 67R37 KAF67R37		0.18	820	0.34	4082	K 97R57 KF 97R57 KA 97R57 KAF97R57	0.18
	1.7	806					0.39	3583		
	2.0	699					0.45	3108		
	2.3	615		0.51			2757			
	2.6	544		0.58	2419		0.25			
	2.9	473		0.66	2123					
	3.3	421		0.75	1856					
	3.8	362		0.86	1625		0.37			
	4.4	319		0.98	1430					
	5.1	273		1.1	1261		0.55			
5.8	240	1.3	1102							
6.5	215	1.5	957	0.75						
7.2	192	1.6	855							
8.4	166	1.9	743	1.1						
9.9	141	2.1	651	1.5						
11	126	2.4	573	2.2						
820	1.2	1171	K 77R37 KF 77R37 KA 77R37 KAF77R37	0.25	1550	2.8	504		0.25	
	1.3	1034				3.2	437			
	1.5	903				3.6	382			
	1.8	793				4.1	342			
	2.0	697		0.59		2370				
	2.3	613		0.68		2050	0.18			
	2.6	542		0.78		1772				
	3.0	471		0.92		1514				
	3.3	420								
	3.9	361								
4.3	323									
5.1	272									
5.8	240									
6.4	217									
7.3	191									



表上所配功率均有超载, 按实际条件确定的转矩不得大于减速机额定转矩。

The power are all overload in the table. The decided torque according to operating condition should not more than gear units' nominal torque.



Mamax Permissible torque Nm	输出转速 Output speed r/min	传动比 Ratio i	机型号 Type Type	功率 Power kW/4p	Mamax Permissible torque Nm	输出转速 Output speed r/min	传动比 Ratio i	机型号 Type Type	功率 Power kW/4p							
4300	4.6	305	K 97R57 KF 97R57 KA 97R57 KAF97R57	3.0	13000	1.5	899	K 127R77 KF 127R77 KA 127R77 KAF127R77	3.0							
	5.4	258				1.8	790									
	6.0	232				2.0	690									
	7.1	199				2.3	599			4.0						
2.6			539													
8000	0.13	10528	K 107R77 KF 107R77 KA 107R77 KAF107R77	0.18		3.0	468			K 127R87 KF 127R87 KA 127R87 KAF127R87	5.5					
	0.15	9391				3.4	410									
	0.17	8211				2.6	536					4.0				
	0.19	7167				0.25	2.9					473	5.5			
							0.23					6097		3.3	418	
					0.25		5582	3.8	367							
					0.27		5065		4.2			330				
	0.32	4299			0.37	4.8	290	7.5								
									0.37			3757				
									0.43			3236	0.55	0.08	17679	0.55
	0.56	2504			0.10	14721										
	0.63	2203					0.11	13097								
	0.74	1869							0.75			11368	1.1			
														0.83	1689	0.12
	0.91	1533			0.14	8718										
	1.1	1317					0.16	7734								
	1.2	1150							1.5			0.18	734	1.5		
															1.4	1015
					1.6	871									0.31	4514
1.8			782	2.2	3974											
	2.0	686				0.35	3516									
2.3	606	3.0	3047					K 157R97 KF 157R97 KA 157R97 KAF157R97	1.5							
										2.7	515	0.48	2899			
3.1	455			0.60	2319											
3.6	402					4.0	0.69			2026						
		4.1	351					0.77	1802							
4.7	307	5.5	0.83								1680	2.2				
				5.2	277								1.0	1365		
				5.9	243	1.1	1229									
				0.08	17550			0.18	1.3	1093					3.0	
0.09	16006	1.5	942													
0.10	14975										1.6	854				
0.11	12440					1.8	756									
0.13	10914			0.25	2.1			661								
		0.14	9819						2.5	565						
0.16	8443	0.37	2.9								503	7.5				
						0.19	7483						3.3	433		
0.21	6565			0.55	5.0	290	11									
								0.24	5804	4.8					307	
0.28	5027	K 157R107 KF 157R107 KA 157R107 KAF157R107	5.6					260								
0.31	4423								6.2		237					
0.37	3801			7.0	210											
0.43	3237					0.07	19653									
0.47	2941	0.08	17345													
0.55	2548							0.75	0.09	14945						
				0.63	2218						0.11	13190				
0.72	1926			1.1	0.12	11532										
0.79	1757	1.5	0.14				10227									
								0.90	1541	0.16			8597			
1.0	1342							2.2	0.21		6538	0.55				
				1.2	1177	K 167R97 KA 167R97								0.16	8597	
		1.4	1025	0.26	5366											
		0.29	4798				0.29			4798						
0.34	4059							0.34	4059							

K

表上所配功率均有超载, 按实际条件确定的转矩不得大于减速机额定转矩。 The power are all overload in the table. The decided torque according to operating condition should not more than gear units' nominal torque.



Mamax Permissible torque Nm	输出转速 Output speed r/min	传动比 Ratio i	机型号 Type Type	功率 Power kW/4p	Mamax Permissible torque Nm	输出转速 Output speed r/min	传动比 Ratio i	机型号 Type Type	功率 Power kW/4p
32000	0.42	3359	K 167R97 KA 167R97	2.2	50000	2.0	720	K 187R107 KA 187R107	15
	0.52	2741				2.4	614		
	0.63	2252		3		18.5			
	0.65	2174		4		30			
	0.85	1698		5.5		37			
	1.0	1402		7.5		45			
	1.1	1291		11					
	1.3	1101		15					
	1.5	944		18.5					
	1.7	843		22					
	1.9	757	30						
	2.6	561	37						
	3.0	479	45						
	3.4	422							
	3.9	367							
	4.7	313							
	5.4	273							
	5.9	250							
	6.7	218							
	7.2	203							
7.9	185								
9.0	163								
11	139								
12	121								
50000	0.04	32625	K 187R97 KA 187R97	0.55	50000	0.05	27165	K 187R97 KA 187R97	0.75
	0.06	24353				0.07	19144		
	0.07	19144				0.08	16978		
	0.08	16978				0.10	14272		
	0.10	14272		0.11		13116			
	0.11	13116		0.12		11647			
	0.12	11647		0.13		10413			
	0.13	10413		0.15		9363			
	0.15	9363		0.17		8126			
	0.17	8126		0.19		7333			
	0.19	7333	0.21	6738					
	0.21	6738	0.24	5984					
	0.24	5984	0.27	5350					
	0.27	5350	0.30	4810					
	0.30	4810	0.33	4364					
	0.33	4364	0.39	3609					
	0.39	3609	0.46	3062					
	0.46	3062	0.56	2519					
	0.56	2519	0.63	2268					
	0.63	2268	0.69	2054					
0.69	2054	0.78	1821						
0.78	1821	0.88	1605						
0.88	1605	1.0	1395						
1.0	1395	1.2	1196						
1.2	1196	2.0	737						
2.0	737	2.4	619						
2.4	619	2.8	524						
2.8	524								

表上所配功率均有超载, 按实际条件确定的转矩不得大于减速机额定转矩。 The power are all overload in the table. The decided torque according to operating condition should not more than gear units' nominal torque.

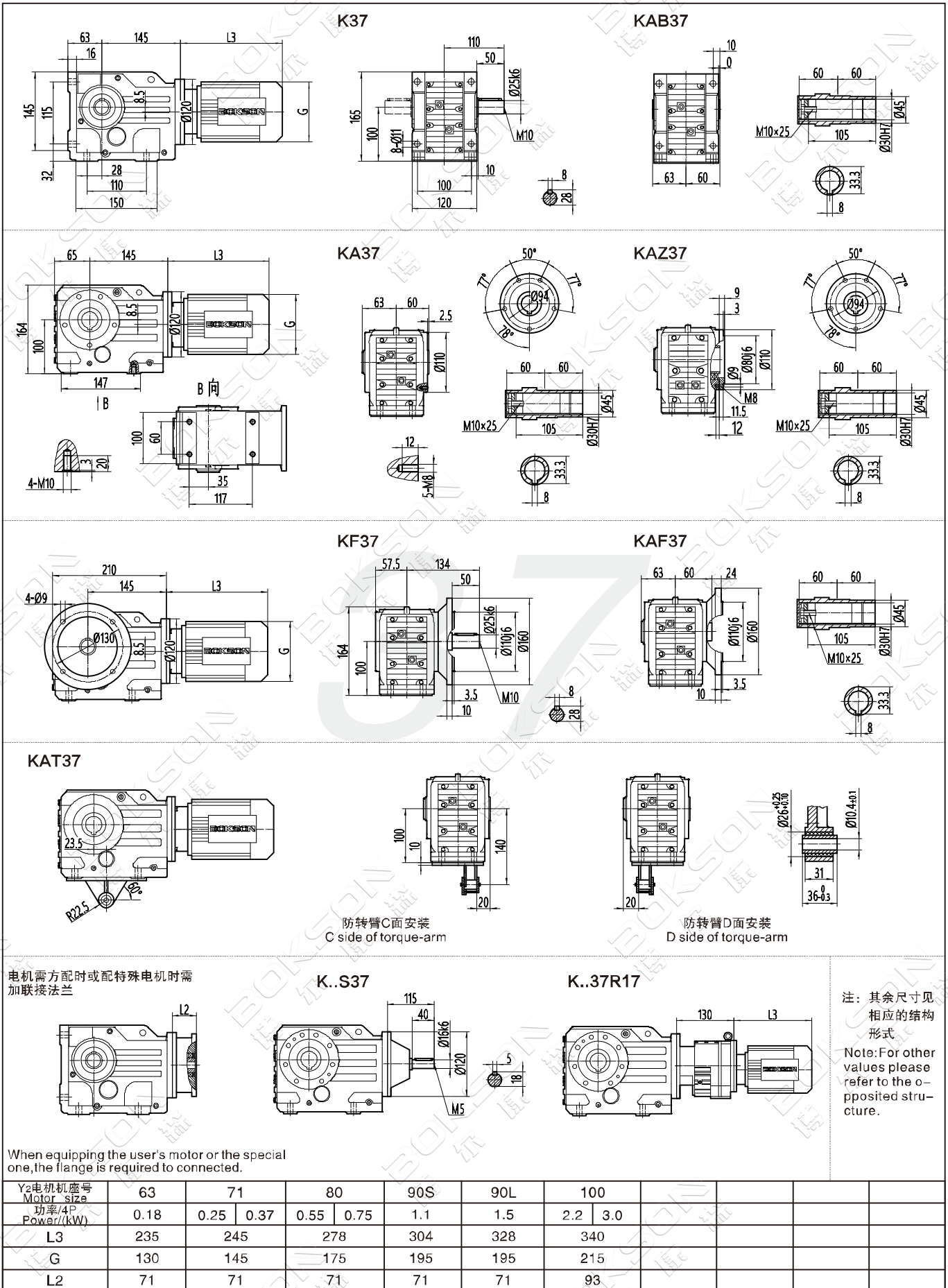

K

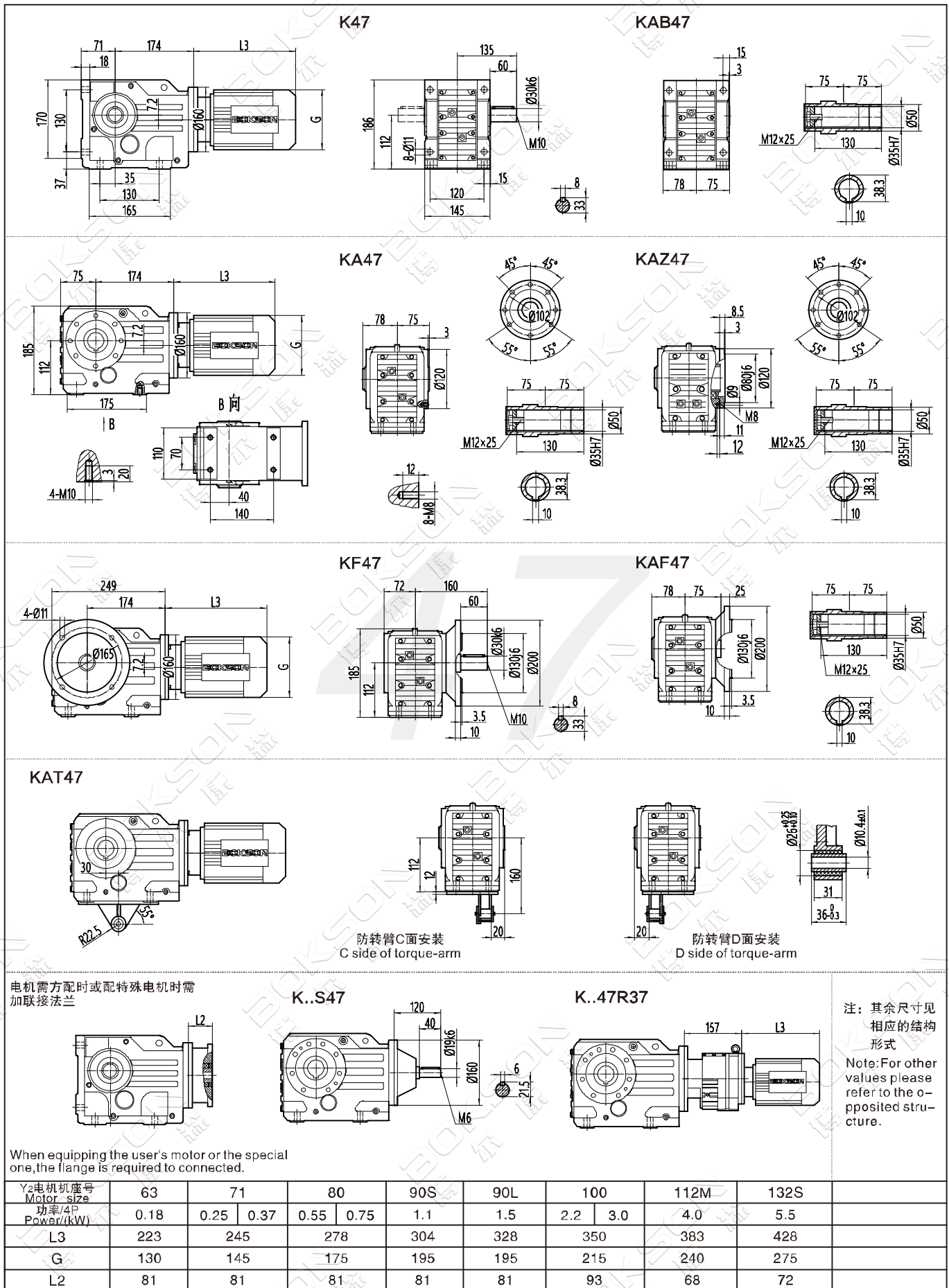

K

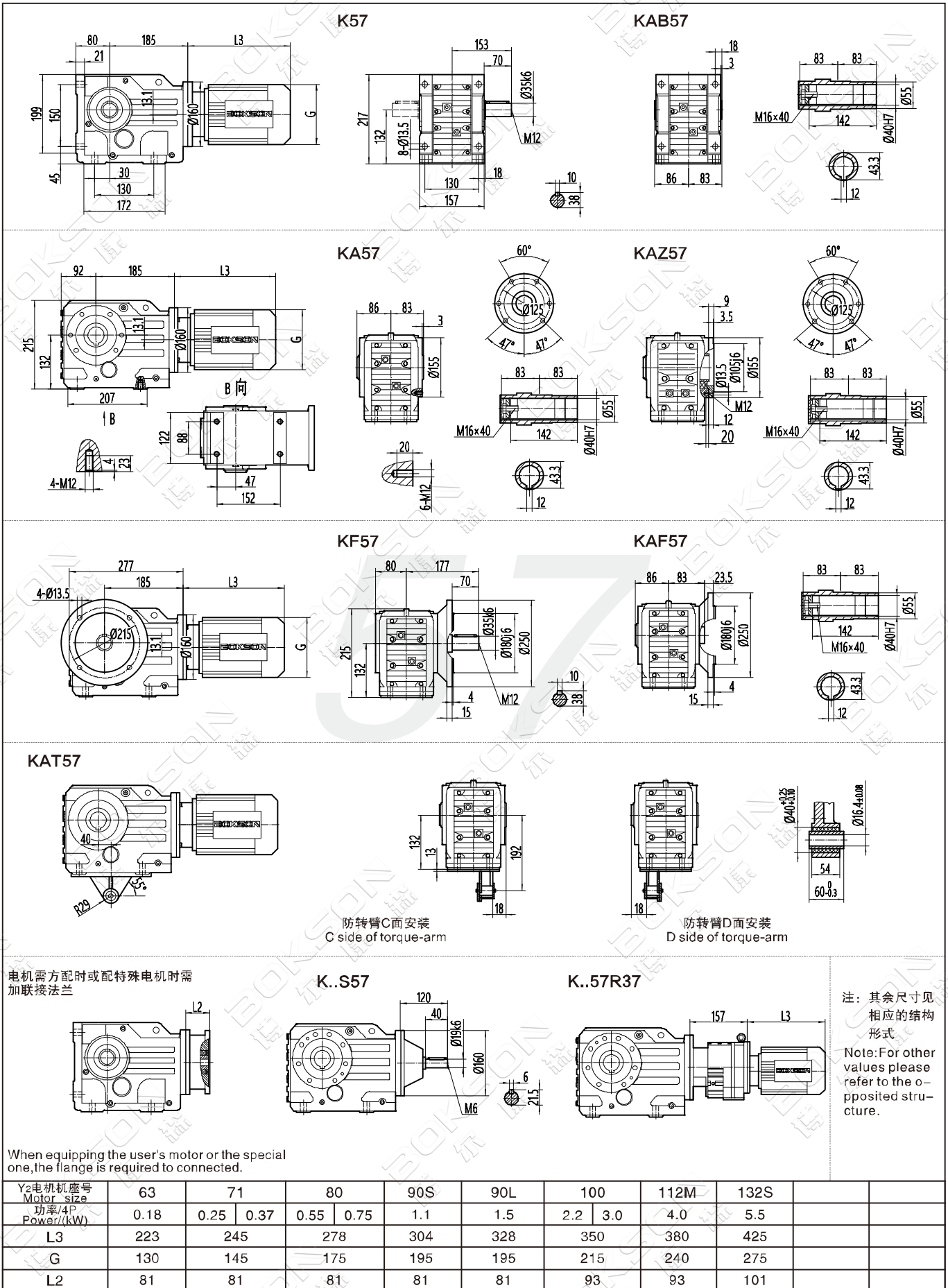

K

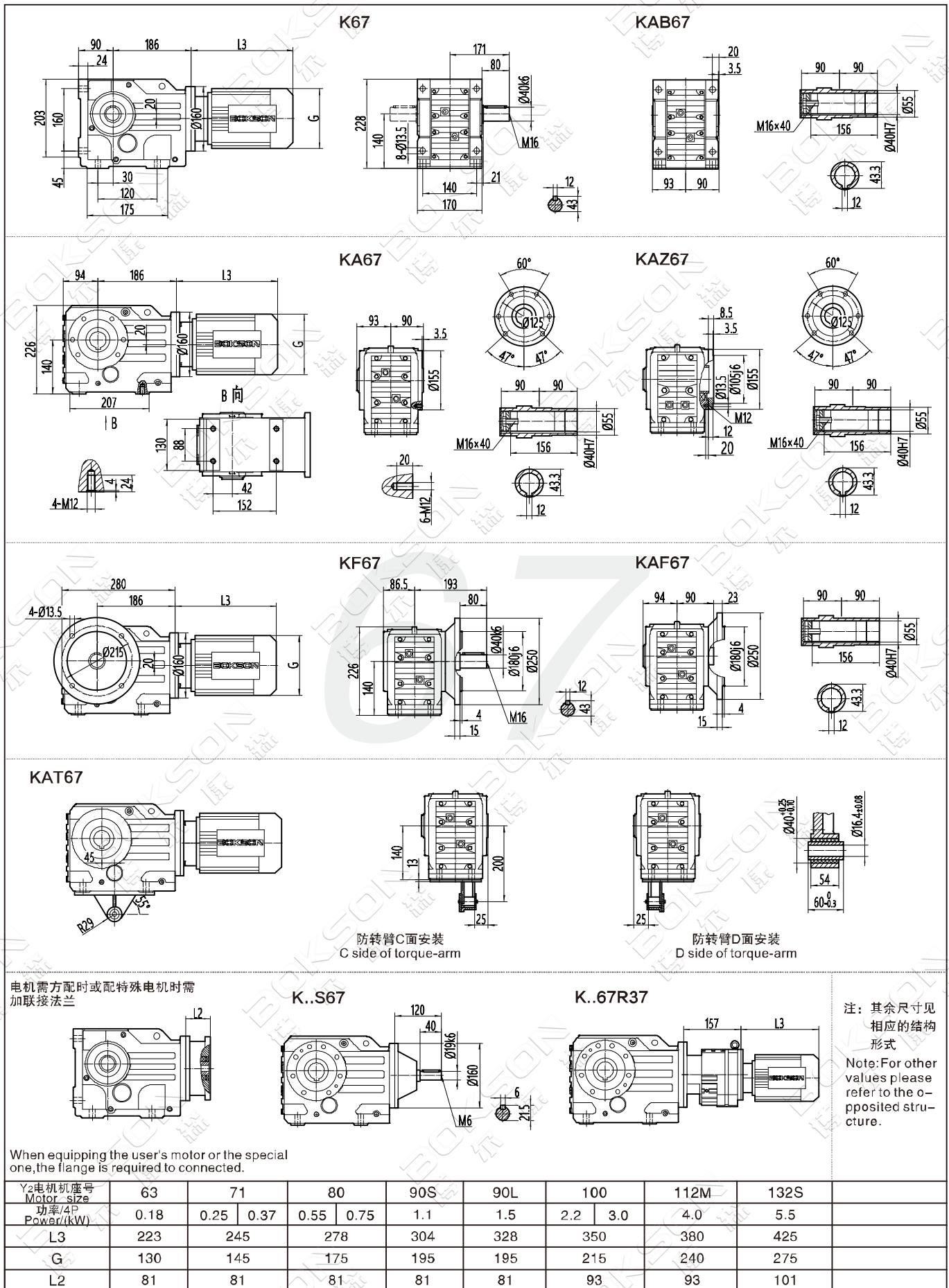

注: 1.KA、KF、KAF、KAZ壳体为通用件, 安装尺寸均可相互参照 2."K.."表示K、KA、KF、KAF、KAZ、KAB
Note: 1.The housings of KA、KF、KAF、KAZ are common parts.The mounting dimensions may consult each other. 2."K.."mean K、KA、KF、KAF、KAZ、KAB.

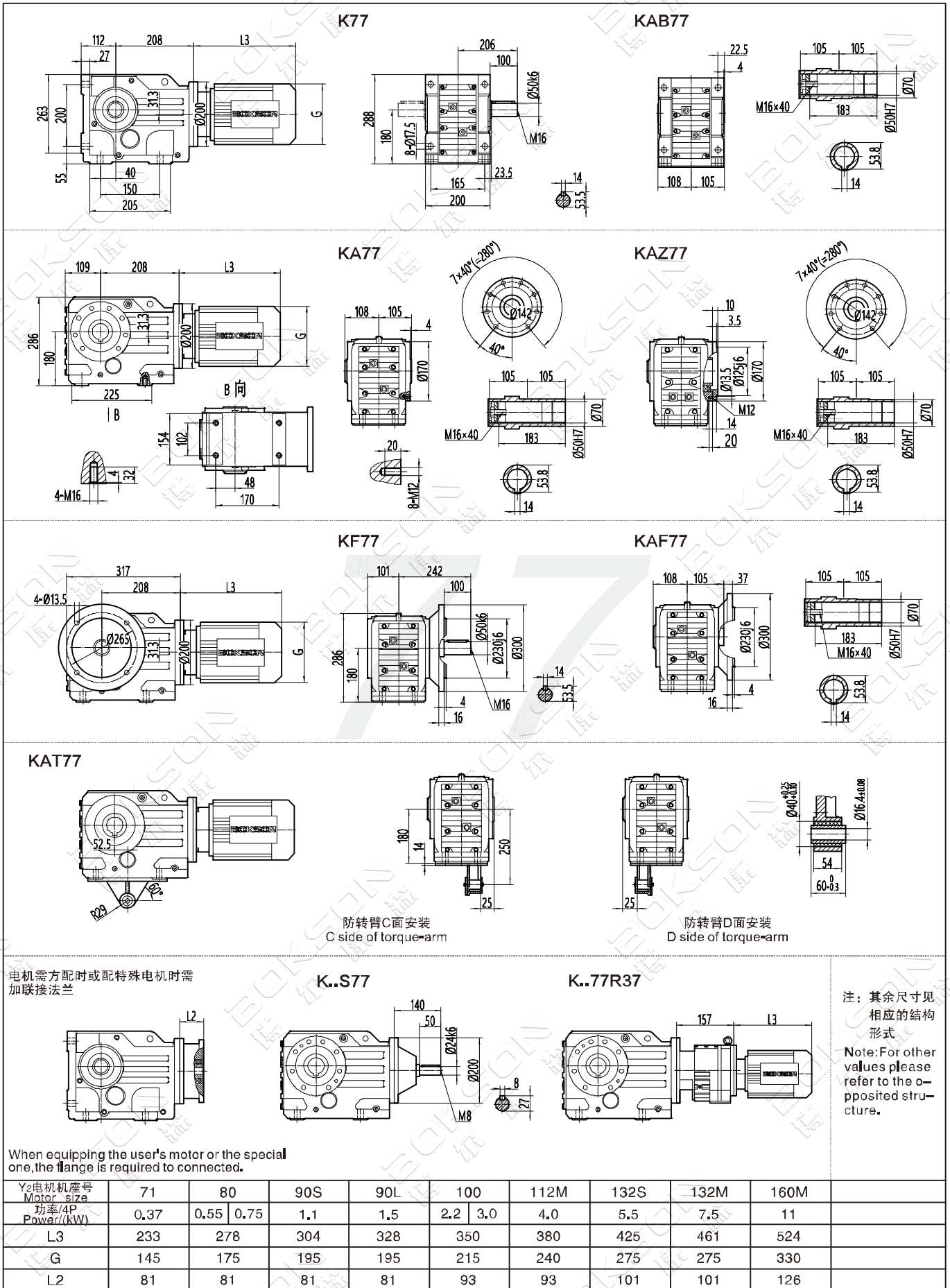

When equipping the user's motor or the special one, the flange is required to be connected.

Y2电机座号 Motor size	71	80	90S	90L	100	112M	132S	132M	160M
功率/4P Power/(kW)	0.37	0.55 0.75	1.1	1.5	2.2 3.0	4.0	5.5	7.5	11
L3	233	278	304	328	350	380	425	461	524
G	145	175	195	195	215	240	275	275	330
L2	81	81	81	81	93	93	101	101	126

注：1.KA、KF、KAF、KAZ壳体为通用件，安装尺寸均可相互参照。2."K.."表示K、KA、KF、KAF、KAZ、KAB
Note: 1. The housings of KA、KF、KAF、KAZ are common parts. The mounting dimensions may consult each other. 2. "K.." mean K、KA、KF、KAF、KAZ、KAB.

K87

KAB87

KA87

KAZ87

KF87

KAF87

KAT87

防转臂C面安装
C side of torque-arm

防转臂D面安装
D side of torque-arm

K..S87

K..87R57

电机需方配时或配特殊电机时需加联接法兰

When equipping the user's motor or the special one, the flange is required to be connected.

Y ₂ 电机机座号 Motor size	80	90S	90L	100	112M	132S	132M	160M	160L	180M	180L
功率/P Power/(kW)	0.75	1.1	1.5	2.2	3.0	4.0	5.5	7.5	11	15	22
L3	246	280	304	350	380	425	461	524	547	583	616
G	175	195	195	215	240	275	275	330	330	380	380
L2	86	86	86	71	71	101	101	126	126	126	126

注: 1.KA、KF、KAF、KAZ壳体为通用件, 安装尺寸均可相互参照。2."K.."表示K、KA、KF、KAF、KAZ、KAB
Note: 1.The housings of KA、KF、KAF、KAZ are common parts. The mounting dimensions may consult each other. 2."K.."mean K、KA、KF、KAF、KAZ、KAB.

注: 其余尺寸见相应的结构形式
Note: For other values please refer to the opposed structure.



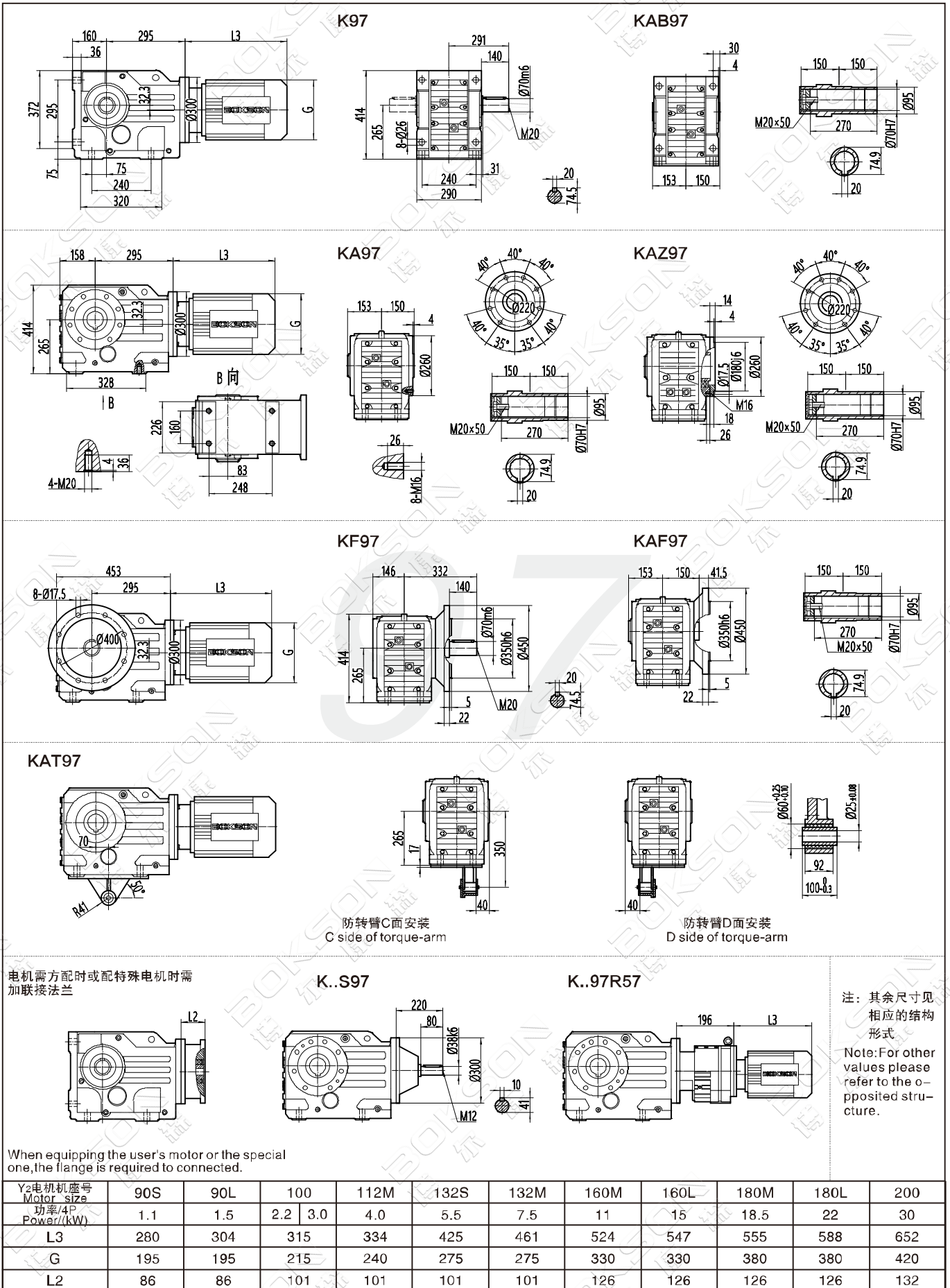

K

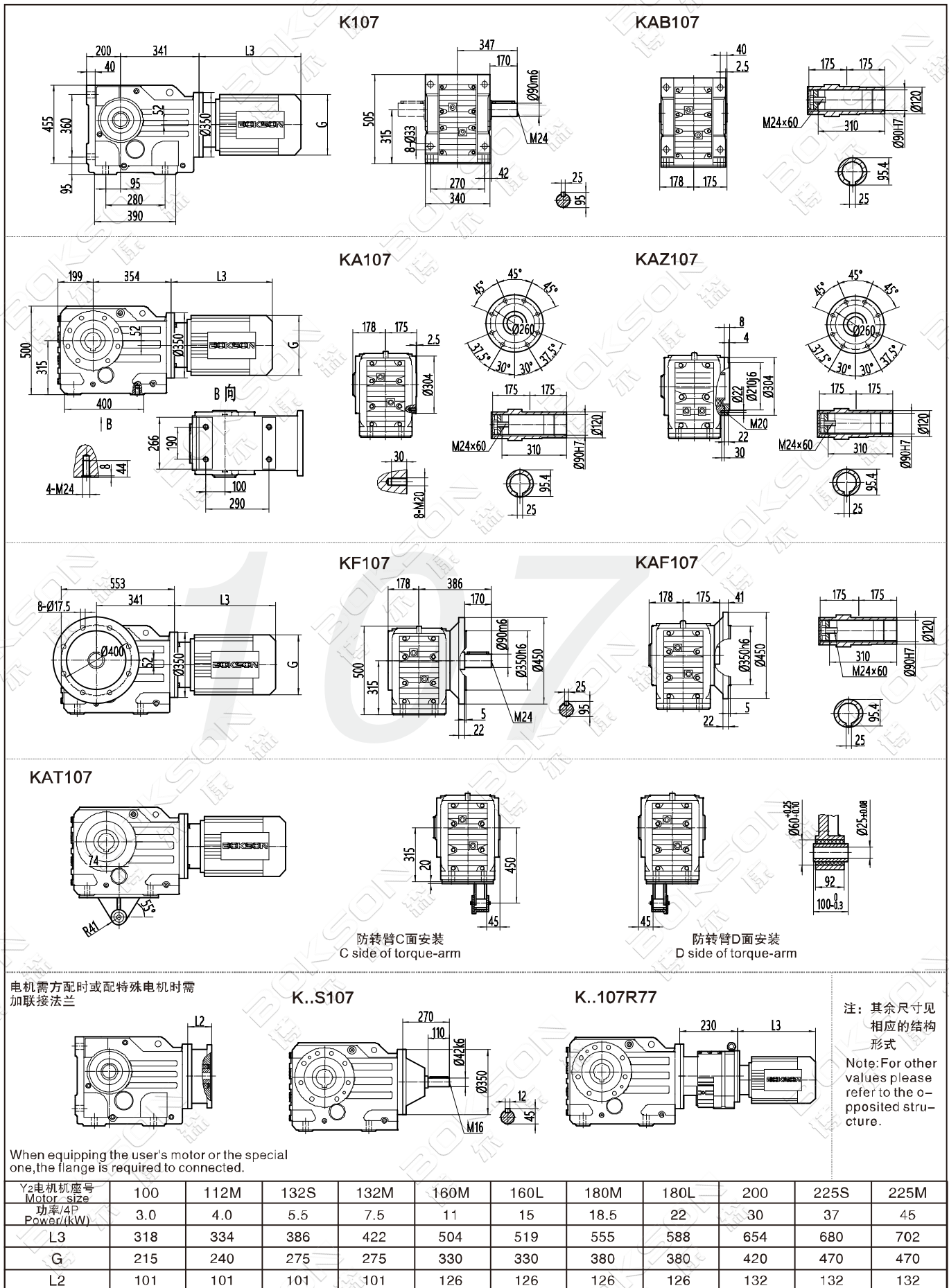

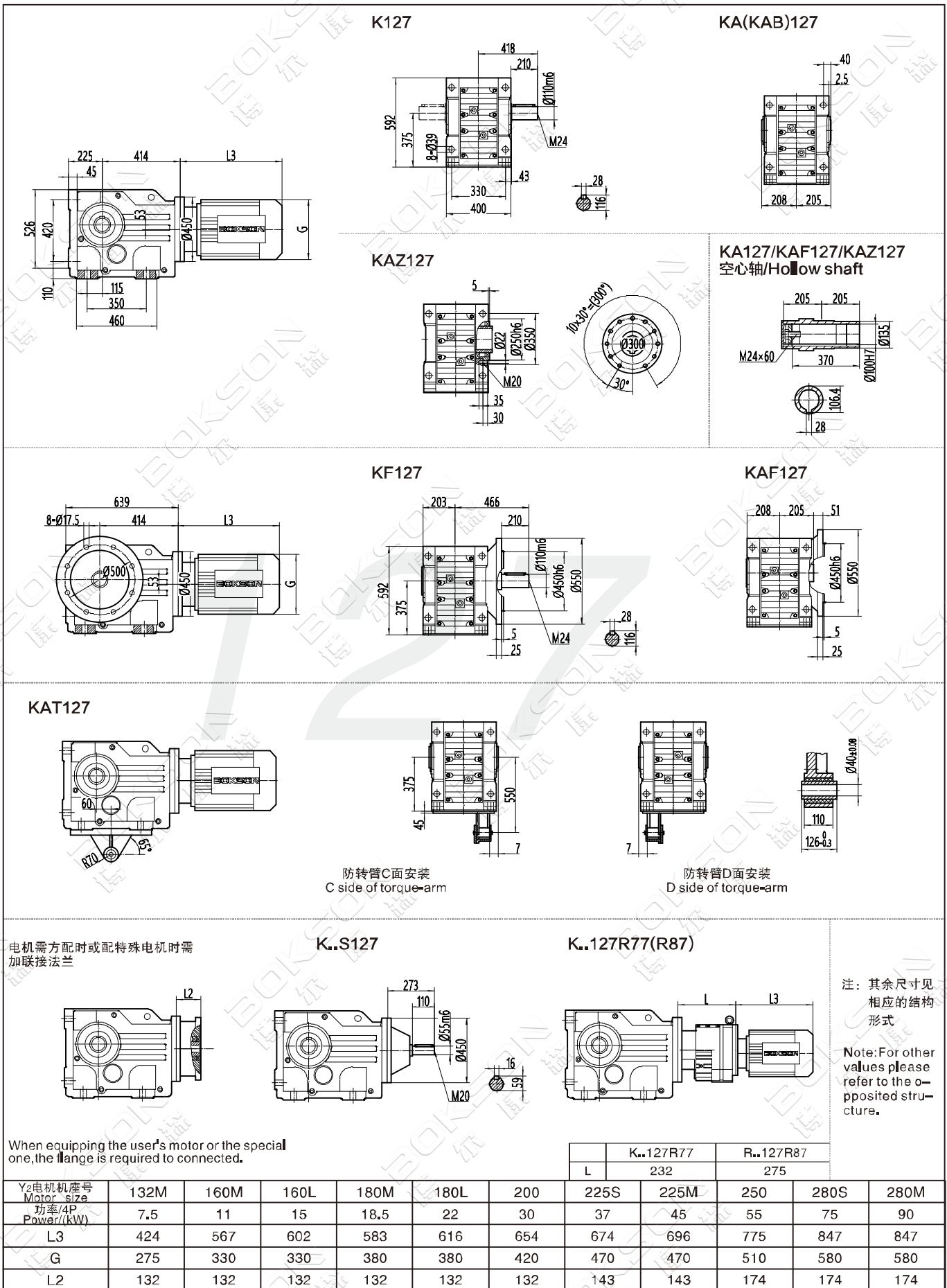

When equipping the user's motor or the special one, the flange is required to connected.

	K..127R77	R..127R87
L	232	275

Y2电机座号 Motor size	132M	160M	160L	180M	180L	200	225S	225M	250	280S	280M
功率/4P Power/(kW)	7.5	11	15	18.5	22	30	37	45	55	75	90
L3	424	567	602	583	616	654	674	696	775	847	847
G	275	330	330	380	380	420	470	470	510	580	580
L2	132	132	132	132	132	132	143	143	174	174	174

注: 1. 以上壳体为通用件, 安装尺寸均可相互参照。

2. "K.."表示K、KA、KF、KAF、KAZ、KAB。

Note: 1. The housings of KA、KF、KAF、KAZ are common parts. The mounting dimensions may consult each other. 2. "K.."mean K、KA、KF、KAF、KAZ、KAB.



K157

KA(KAB)157

KAZ157

KA157/KAF157/KAZ157 空心轴/Hollow shaft

KF157

KAF157

KAT157

防转臂C面安装
C side of torque-arm

防转臂D面安装
D side of torque-arm

K..S157

K..157R97(R107)

注: 其余尺寸见相应的结构形式
Note: For other values please refer to the opposite structure.

电机需方配时或配特殊电机时需加联接法兰
When equipping the user's motor or the special one, the flange is required to connected.

	K..157R97				R..157R107								
	L	320	370										
Y ₂ 电机机座号 Motor size	160M	160L	180M	180L	200	225S	225M	250	280S	280M	315S	315M	315L
功率/4P Power/(kW)	11	15	18.5	22	30	37	45	55	75	90	110	132	160
L3	567	602	635	666	642	669	691	770	828	879	1100	1180	1270
G	330	330	380	380	420	470	470	510	580	580	645	645	645
L2	143	143	143	143	143	143	143	143	143	143	145	145	145



注: 1. 以上壳体为通用件, 安装尺寸均可相互参照。 2. "K.."表示K、KA、KF、KAF、KAZ、KAB。
 Note: 1. The housings of KA、KF、KAF、KAZ are common parts. The mounting dimensions may consult each other. 2. "K.." mean K、KA、KF、KAF、KAZ、KAB.

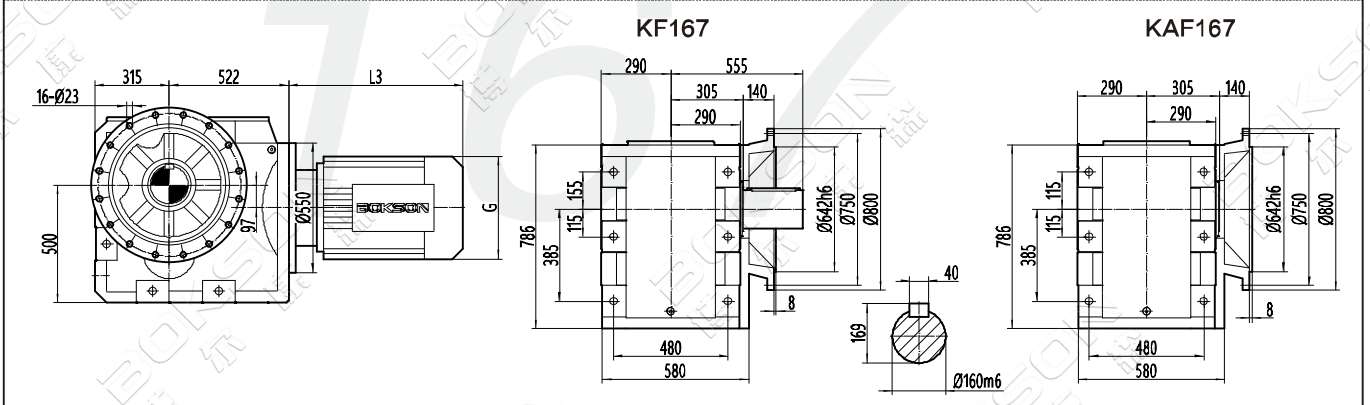
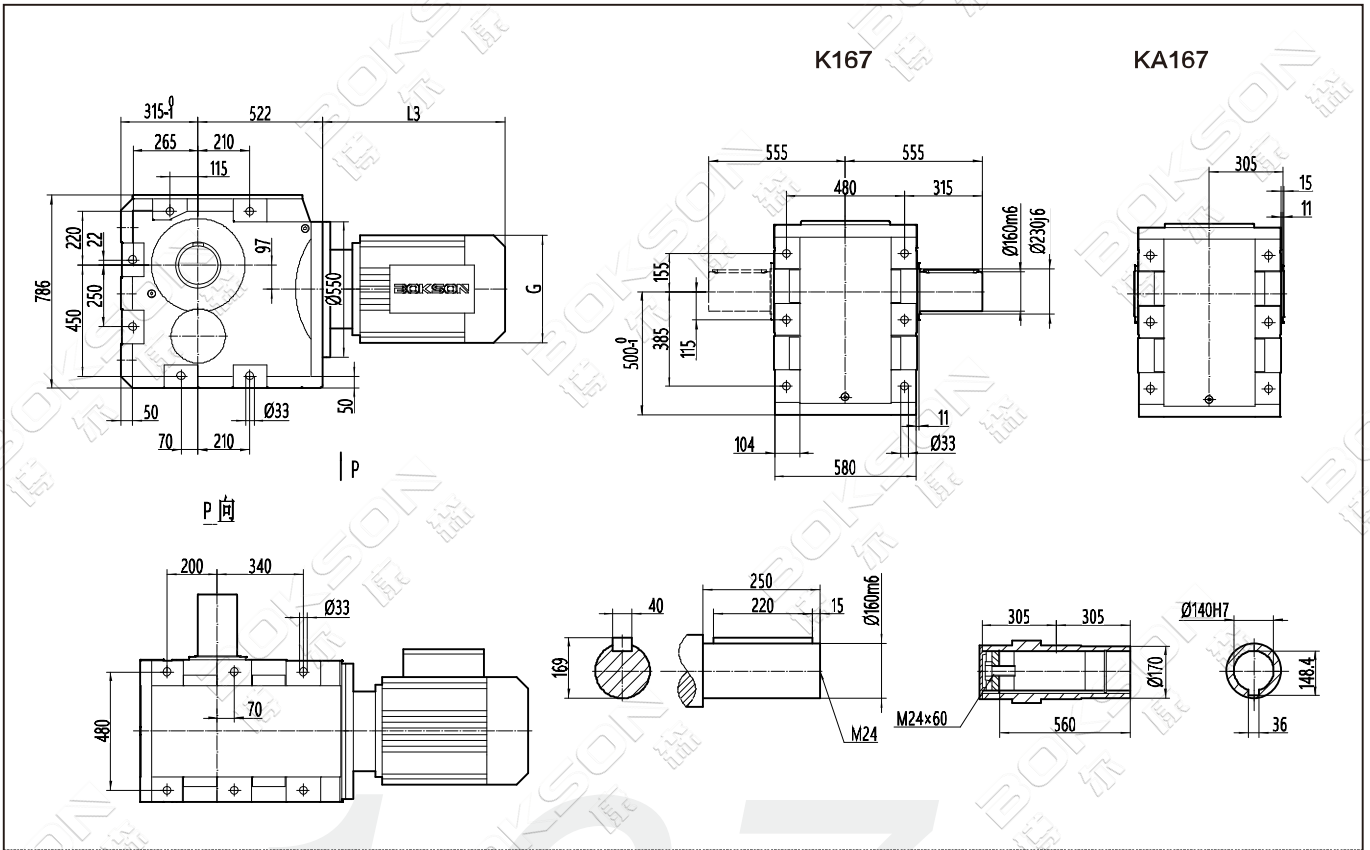

电机需方配时或配特殊电机时需加联接法兰

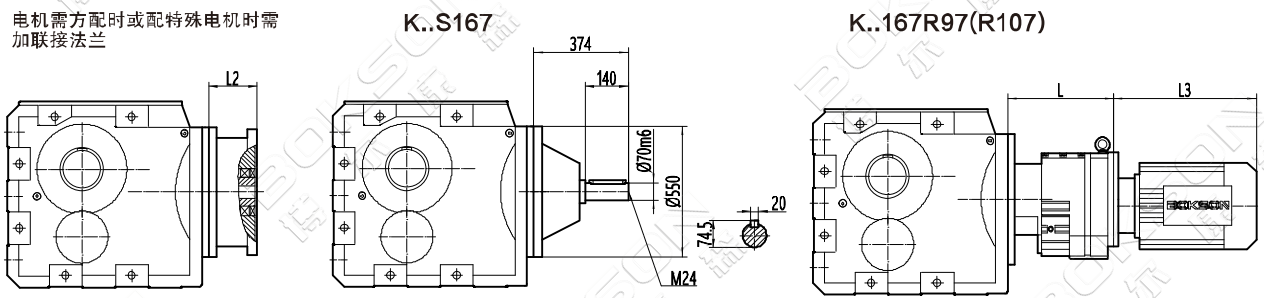

When equipping the user's motor or the special one, the flange is required to be connected.

注：其余尺寸见相应的结构形式

Note: For other values please refer to the opposited structure.

Y ₂ 电机机座号 Motor size	160M	160L	180M	180L	200L	225S	225M	250M	280S	K..167R97		K..167R107		
										L	320	355		
功率/4P Power/(kW)	11	15	18.5	22	30	37	45	55	75	90	110	132	160	200
L3	492	537	593	633	646	673	698	779	847	847	1100	1180	1270	
G	330	330	380	380	420	470	470	510	580	580	645	645	645	
L2	76	76	76	76	76	98	98	103	103	103	132	132	132	

注：1.KA、KF、KAF、KAZ壳体为通用件，安装尺寸均可相互参照。2."K.."表示K、KA、KF、KAF、KAZ、KAB

Note: 1.The housings of KA、KF、KAF、KAZ are common parts.The mounting dimensions may consult each other. 2."K.."mean K、KA、KF、KAF、KAZ、KAB.

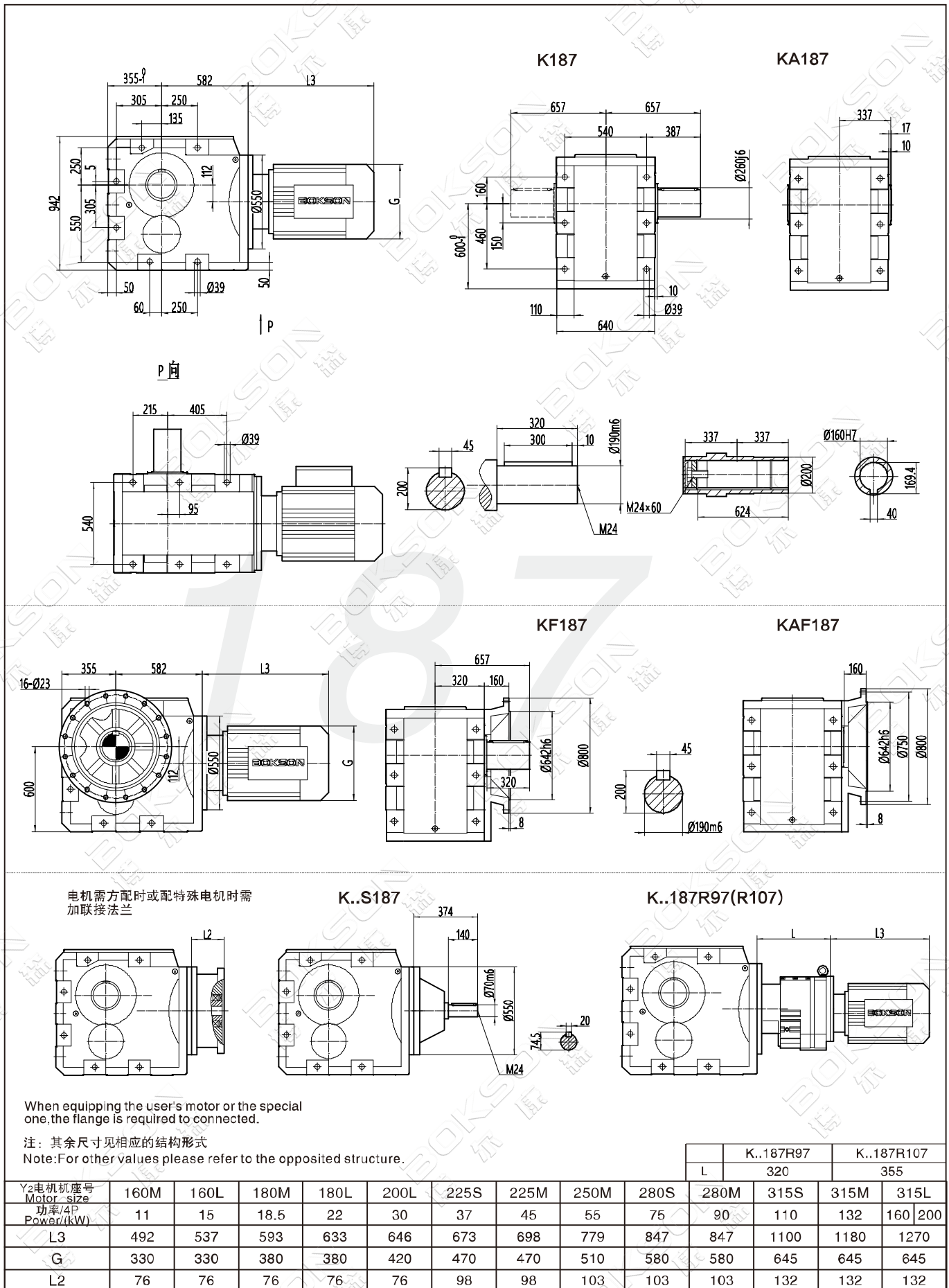

注：1.KA、KF、KAF、KAZ壳体为通用件，安装尺寸均可相互参照。2."K.."表示K、KA、KF、KAF、KAZ、KAB
Note: 1.The housings of KA、KF、KAF、KAZ are common parts. The mounting dimensions may consult each other. 2."K.."mean K、KA、KF、KAF、KAZ、KAB.